

LABORATORY MODEL TESTS TO STUDY THE BEHAVIOR OF SOIL WALL REINFORCED BY WEAK REINFORCING LAYERS

*M. Vafaeian**

*Department of Civil Engineering, Isfahan University of Technology (IUT)
Post Code 8415683111, Isfahan, Iran
mahmood@cc.iut.ac.ir*

R. Abbaszadeh

*Department of Civil Engineering, Islamic Azad University
P.O. Box 84175/119, Khomainsahr, Iran
Rezaabbaszadeh50@yahoo.com*

*Corresponding Author

(Received: July 1, 2006 – Accepted in Revised Form: May 9, 2008)

Abstract A series of laboratory experiments have been performed to observe the behavior of the geosynthetically reinforced soil in small scale model. In these tests the effect of reinforcement tensile strength and their vertical interval spacing have been examined under the plane strain conditions. The reinforced soil was modeled in a laboratory container with the dimensions of 120 cm (height), 100 cm (length), and 20 cm (width). Because the main goal of this investigation was to observe the effect of external surface loading (to simulate the traffic loads) on the stability and failure of these types of geosynthetically reinforced embankments, so suitable assembly of loading processes has been arranged for this purpose. The reinforcement elements were the cotton papers of very low tensile strength, values from 0.06 to 0.7 kN/m. In order to interpreting the results, various amounts of affecting parameters and different options of computing formulae have been examined in the computations. It was found that the best computation formula is the modified Bishop's formula in which the tensile strength of reinforcing elements and the effect of side wall friction can be taken into account.

Keywords Reinforced Soil, External Load, Failure, Safety Factor

چکیده به منظور بررسی رفتار خاک مسلح در دیوار حایل، آزمایش هایی در مقیاس مدل آزمایشگاهی روی خاک ماسه ای مسلح شده با لایه های نازک تسلیح انجام گرفت. لایه های تسلیح از نوع کاغذ و با مقاومت ناچیز (درحد ۰.۷ کیلونیوتن بر متر و کمتر) انتخاب گردید. در این آزمایش ها، به منظور مشاهده سطح گسیختگی تشکیل شده در خاک و دانستن بار مرتبط با آن، بار وارد بر سطح خاک به صورت تدریجی و مرحله ای و به وسیله وزنه های با وزن معین افزایش داده شد تا خاک به مرحله گسیختگی برسد. از نتایج این آزمایش ها مشخص گردید که مناسب ترین رابطه تحلیلی در این مورد، رابطه اصلی بیشاپ است مشروط به آنکه تأثیر تمام مؤلفه های نیروها حاصل از بار خارجی و وزن ذاتی خاک و همچنین اثر اصطکاک جدار بین خاک و جدار ظرف آزمایش در نظر گرفته شود.

1. INTRODUCTION

During the last three decades, i.e. since the time of first Int. Conference on Geosynthetics (in Paris, 1977) up to the present time, seven other international conferences have been held on this subject in which enormous number of relevant

articles have been presented in the proceedings. During this time many books and reports have been published on various aspects of soil reinforcement and the subject of geosynthetics.

In 32nd Terzaghi Lecture in the year 2000, Koerner [1] presented a table containing 17 topics of geosynthetic application in 4 groups

(Geotechnical, Transportations, Hydraulics and Geoenvironmental). He also presented a diagram illustrating the growth of different aspects of quantity and sales of geosynthetics in North America, based on which he indicated, the approximate sales of these materials in the North America were \$2.5 billion in 1988 [1].

Presently, great researches and advancements have been done and made in the area of soil reinforcement, either theoretically, analytically, numerically or experimentally. Many experimental studies have been reported either from small laboratory scales without centrifuge apparatus or from the full scale models within the ordinary gravity field. The major objectives of the experimental efforts can be attributed to the following subjects:

- a. The factor of safety for soil-reinforcement system in slopes and walls against sliding, pooling out the reinforcements, settlement and lateral deformations.
- b. Effect of tensile strength and tensile stiffness of the reinforcements.
- c. Peak or residual angle of soil friction.
- d. Shape and location of shear or failure zone.
- e. Optimizing the reinforcements for the location and the number of reinforcing layers.
- f. Effect of external surface loads on the stability and behavior of the reinforced soil medium.
- g. Effect of inclination of wall face on the stability.
- i. Effect of the slope of reinforcement layers on the whole behavior.

In the following, few of relevant examples of recent literature are cited:

The laboratory study by Lee, et al [2] may be considered as the first detailed laboratory experiments in small models (without the centrifuge apparatus) in which the reinforcement was made by some weak metal strip bands. In their tests the effect of strips strength and the friction angle of soil were studied on the final stable height of reinforced retaining wall in a laboratory scale, i. e. within the dimensions of 160 cm long, 76 cm wide and different height up to 60 cm. They concluded that the results from their tests could be a

coincident with both Coulomb and Rankine wedges with a little difference, but the relative density (or the friction angle) of soil had not shown any significant effects on the overall strength of soil-reinforcement system. They also measured the tension stresses within the strands and found the distribution of this stress along the height of the wall. Referances will be made again to this paper.

Examples of results from centrifuge models have been reported by Porbaha, et al [3] and Zornberg, et al [4] regarding the shape of the failure surface and the reliability of analytical discussions.

Juran, et al [5] described the results of a laboratory model study on the performance and behavior of reinforced soil retaining walls using different reinforcing materials, namely: woven polyester, geo-textile strips, plastic grids, and non-woven materials. The model walls in their studies were instrumented to obtain measurement of stresses in the reinforcements of facing. The models in their experiments were built in a box of 110 cm tall, 150 cm long and 90 cm wide with plexiglass side walls. The soil used in their tests was a fine sand (average grain diameter 0.1 mm) with the maximum dry unit weight from 17kN/m^3 to 14.4 kN/m^3 . The tests were conducted with the soil having dry unit weight between 15.3 and 15.7 kN/m^3 , the range of friction angle corresponding to these values were 40 to 45 degrees within the stress level of less than 10 kPa which is the stress field of laboratory range. They also showed the trend of decreasing the values of soil friction angle (measured by direct shear tests) with increasing the applied normal stresses. Their results will be referred to later.

The height of the model soil wall in their tests were 56, 65, and 80cm with the reinforcement interval spacing as 5cm. The major parts of their studies were concentrated on the measurements of tensile force inside the reinforcement, and measuring the displacements for their different types of reinforcement elements. The failure surface in these tests was coincident with Coulomb's wedge theory.

Zornberg, et al [6] reported a list of 13 experimental studies on real cases of reinforced slopes or embankments with the heights between 2.7 m to 7.6 m including one case with 27.4 m height.

2. SCOPE OF TESTING EQUIPMENTS AND TEST PROCEDURE

The model container, consisting of a box with dimensions of 20 cm (breadth), 120 cm (height in two parts of 60 cm) and 100 cm (length) with two sides of 6mm thick glass walls. A schematic view is shown in Figure 1. The selected soil is a sand (SP in Unified Soil Classification) with grain size distribution between 0.1 and 2 mm. Reinforcement layers were selected of thin cotton papers, in one or two layers and different spacing. The wall facing was made of pieces of wooden blocks with two different heights (5.5 and 11 cm) as shown in Figure 1. In the primary tests the facing blocks were selected from yunulith pieces, but it was found that they were not strong enough to stand.

Building up the proposed laboratory model consisted of the following steps; The first block of facing was placed on the floor of the container at the planned point and it was fixed by a thrust to be able to hold the first sand layer. The required amount of sand for each layer of sand (the height of either 5.5 cm or 11 cm) was weighed previously and then was poured into the container by raining procedure from a suitable hopper which was moved along the length of the container uniformly and at a constant calibrated height. By this method the density of deposited sand which was to be constant and uniform along the length and also along the height was achieved. After pouring each layer of sand, a layer of reinforcement paper (which was stocken to to the top of the wooden block) was laid on the surface of the poured layer of sand. Then the next block was fixed on the top of the previous block and the next layer of pouring sand was carried out.

The relationship between raining height and the achieved density of sand is shown graphically in Figure 2. The friction angle of sand was measured by the standard direct shear box in different densities and under different vertical loads. Based on these tests the values of peak friction angle were obtained between 32° and 41° dependent on the density and applied vertical load, while the residual values were achieved around 30 to 32°.

The density of soil in each test was measured by some cylindrical pots located inside the container at different levels while filling the container. These pots were weighed after finishing the test and

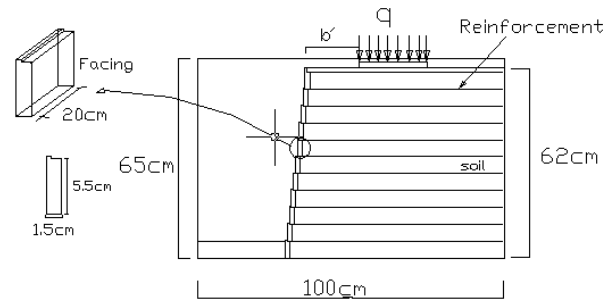

Figure 1. View of the container and the wooden facing.

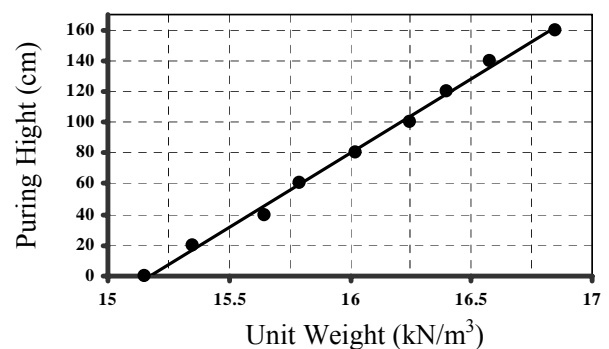

Figure 2. Relationship between the unit weight of soil and the pouring height.

emptying the container, so the density of soil could be determined by calculating the mass and the volume of soil in a single pot. Besides these measurements, the average density of soil was also determined by knowing the overall mass and volume of the soil used in each test.

After filling the container, the loading procedure were made by applying the dead weights in step-wised increments as shown simply in Figure 1.

However, loading by hand jacking was also examined during some trial tests.

The deformations of the soil body (either in vertical or horizontal directions, or along the failure path) on the vertical plane of glass sides were measured by observations, and also by means of digital photography, which was fixed at a constant distance from the model. To determine the deformation pattern, consequent photos were taken during the test, each one after each step of loading.

In order to prevent the unwilling horizontal deflection of the glass wall, and keeping the test procedure under the exact plane strain conditions and also for the confidence of safety, the side glass walls were supported by means of 2 extra steel bars in the middle height on both sides. Also two other bars were fixed on the top of the boundary vertical columns to hold the applied dead loads from falling down.

In order to constitute a reference datum frame for observing and measuring the plane deformation on the vertical sections, a hand drawing mesh with 1 cm intervals was drawn on the inside surface of the side glass wall to prepare a square grid pattern.

3. EXPERIMENT PROGRAM AND THE RESULTS

3.1. Experiments The test program was selected as to be suitable for the planned purposes i.e., to evaluate the effects of different influential factors on the behavior of geosynthetically reinforcement soil wall under surface vertical loads, such as a reinforced soil retaining wall for road embankments. Though there are many parameters that may affect the behavior of geosynthetically reinforced soil, because the laboratory facilities have naturally some limitations, the variables in the present study are limited to: reinforcement of vertical spacing, the number of reinforcement sheets, the tensile strength of reinforcement material, the size of facing elements, soil friction or relative density, and the relative location of loading plate.

In this research, more than 40 laboratory tests have been run. Photos taken during the tests could illustrate the overall views of the failures patterns.

For the ease of discussion and interpretations, it is desirable to classify the tests into some appropriate groups which can refer to them accordingly. The specifications of these tests are shown in Tables 1 to 3. The symbols of the variables in these tests (as indicated in these tables) are:

a (10 or 15cm, b' in Figure 1) distance from the edge of loading plate to the wall,

b	The width of loading plate, $b = 15$ or 18.5 cm.
l	The length of loading plate, 22 cm
h_f	The height of each piece of facing, 5.5 or 11 cm.
s_v	The vertical spacing of reinforcement layers, usually equals to h_f , but in some tests $2h_f$.
H	The final height of wall, 60 cm in most tests
H_{cr}	The final possible height of wall before it fails due to its own weight
T_j	The tensile strength of paper sheets as reinforcement layers (kN/m)
FL	The failure load corresponding the maximum external surface load

Tensile strength of paper sheets was measured by the special device (Zwick system) in the Laboratory of Fibers at Textile Faculty of IUT. The measured stress- strain relationship for these reinforcing sheets are shown in Figure 3a for three selected cases named: SG, MG and WG representing the strong, medium and weak types respectively. As it was anticipated, the measured tensile strength of these sheets were found to be dependent upon the length along which the tension force is applied. Therefore, with increasing the length of the reinforcing piece, the measured tensile strength was decreased. Several tests were performed for this purpose on the reinforcement strips with 5.5cm width and different lengths, from which the range of tensile strength was found to be between 0.45 kN/m (for the longest piece of 11 cm length) to the maximum value of 0.7 kN/m (corresponding to the possible very short length, 0.25 cm) for the type of SG reinforcement (Figure 3b) and 0.065 to 0.1 kN/m for the type of WG. Because the reinforcing sheets are confined within the soil particles during the tests, so it can be accepted that the maximum value of strength is the best relevant value for the computations. Typical results of testing the reinforcing sheets are shown in Figure 3c. The working values for tensile strength of reinforcement elements were chosen as 0.68, 0.32 and 0.1 for SG, MG and WG respectively.

3.2. Discussion on the Tests Results The main results of tests are shown in Tables 1 to 3.

**TABLE 1. Results of Tests, Series D: a= 10 cm, b = 15 cm or 18.5 cm, l = 22 cm
h_f = 5.5 cm, T_j = 0.32 or 0.68 kN/m.**

	Symbol	B(cm)	S	H(cm)	Ext. Load	Remarks
1	D1	15	5.5	110	0.8 (kN)	T _j = 0.32kN/m
2	D1-18	18.5	5.5	60	1.05	T _j = 0.32kN/m
3	D2	15	16.5	110	0.8	T _j = 0.68kN/m
4	D3	15	11	110	Gravity	T _j = 0.68kN/m
5	D4	15	16.5	72	Gravity	T _j = 0.32kN/m
6	D5	15	11	90	Gravity	T _j = 0.32kN/m
7	D6	15	11	110	Jacking	T _j = 0.68kN/m
8	D7	15	5.5	110	Jacking	T _j = 0.32kN/m

**TABLE 2. (Series E): a = 15 cm, b = 11.5, 15 or 18.5 cm, l = 22 cm, h_f = 5.5 cm, H = 60 cm
(See Photo No. 1) T_j = 0.32 kN/m.**

No.	Symbol	b(cm)	Ext. Load (kN)	s _v (cm)
1	E1	15	1.1	5.5
2	E2	15	1.33	“
3	E3	15	1.48	”
4	E4	15	1.37	”
5	E5	15	1.7	”
6	E1-LU	15	1.1	”
7	E1-18	18.5	1.37	”
9	E2-18	18.5	0.8	11

TABLE 3. (Series EW): Similar to Table 3, Except T_j = 0.1 kN/m.

No	Symbol	b(cm)	Ext. Load (k N)	s _v (cm)
1	EW1	15	0.85*	5.5
2	EW1-18	18.5	0.9	5.5
3	EW1-11	11.5	0.8	5.5
4	EW2-18	18.5	0.375	11

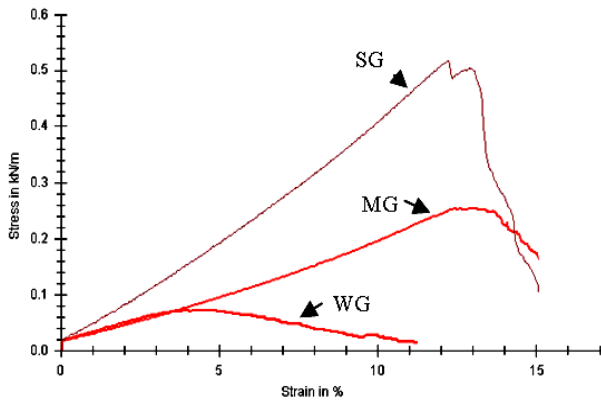

(a)

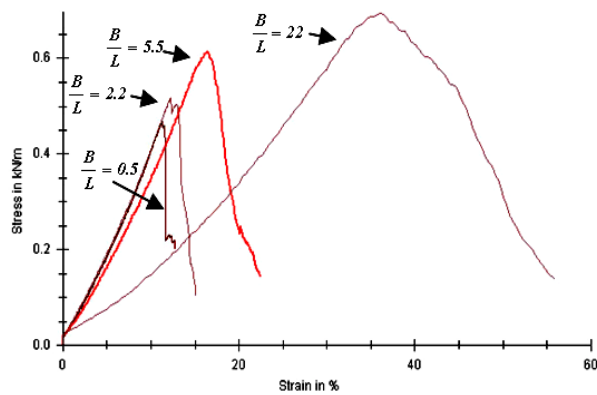

(b)

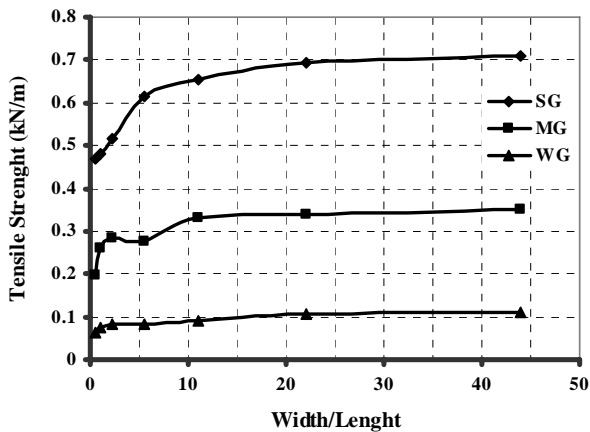

(c)

Figure 3. (a) Measured stress-strain relationship for three types of paper sheets for equal width/length ratio as $B/L = 2.2$ and (b) Measured stress-strain relationship for different ratio of width to length of strong paper sheets (type SG) and (c) Measured tensile strength of unconfined paper sheets as a function of width/length ratio.

As it is expected, the observations and measurements in these series of tests show that promoting the reinforcements (either by increasing the numbers of reinforcing layers or using the reinforcements of higher tensile strength) results in more stability.

For example, tests D4 and D5 (Table 1) are the tests in which the failure occurs due to the gravity (without the external loading); and because the spacing of reinforcement in D4 is 11cm but in D5 is 16.5 cm, so the maximum possible height is more in D4 (110 cm) comparing to D5 (70 cm). Also though in tests D1 and D2 the reinforcement spacing is different (5.5 and 16.5 cm), but because the tensile strength is also different (0.32 kN/m in D2 and 0.68 kN/m in D1) then the final external load is nearly the same. The effect of load position relative to the edge of wall can be observed in comparing test D1 ($a = 10$ cm) and test E1 in Table 2 ($a = 15$ cm) which failed by different external loads i.e. 0.8 and 1.1 kN.

In test E1 (Table 2), there are 10 single layers of reinforcements, the tensile strength of each layer is 0.32kN/m, but in tests E2 to E4 in which three layers of reinforcements became doubled (near the toe in E2, at the mid height in E3 and at the top in E4). In E5 the double layers are arranged alternatively between the single layers(five double layers of 0.68 kN/m). Comparisons between E1 (with the failure load of 1.1 kN) with any of tests E2 (FL = 1.33 kN), E3 (FL = 1.48 kN), E4 (FL = 1.37 kN), and E5 (FL = 1.7 kN) clearly indicate this expecting relationship. The failure load (FL) in these tests is the maximum tolerable load which applied on the loading plate of $l = 22$ cm and $b = 15.5$ cm; therefore for conventional calculations this load must be multiplied by $1/0.22 = 4.55$. Tests E1 and EW1 are identical in layer arrangements, but the tensile strength of reinforcement layers is 0.32 in E1 and 0.2 kN/m in EW1, accordingly the failure loads are 1.1 and 0.85 respectively. Comparing the results of tests EW1-18 (spacing of reinforcing = 5.5 cm) and EW2-18 (spacing of reinforcing layers = 11 cm) is an example to show the effect of vertical spacing of the reinforcement layers. In these tests, the tensile strength of layers is 0.2kN/m and the failure load falls from 0.9 kN (in EW1-18, $s_v = 5.5$ cm) to 0.375 kN (in EW2-18, $s_v = 11$ cm). Similar results are obtained by comparing the tests E1-18 ($s_v = 5.5$

cm, FL = 1.37 kN) and E2-18 ($s_v = 11$ cm, FL = 0.8 kN) in which the tensile strength is 0.1 kN/m for both.

Based on the present experimental results, some simple graphical representations can be drawn to detect the effect of vertical spacing and the tensile strength of the reinforcements. Figure 4 shows the effect of vertical spacing while Figure 5 illustrates the influence of the tensile strength on the final possible vertical surface loads.

Comparison between the tests E1($b = 15$ cm, FL = 1.1 kN) and E1-18($b = 18.5$ cm, FL = 1.37 kN), shows that increasing the width of loading plate results in ascending the failure load proportionally (similarly tests EW 1 and EW 1-18). As the ratio of $1.37/1.1 = 1.24$ is about the same as the ratio $18.5/15$, it means that both of them are still under plane strain conditions. A schematic view of failure pattern corresponding to these tests is shown in Figure 6.

3.3. Side Friction Usually for the laboratory tests in which the plane strain conditions is aimed, two types of model container can be set up:

- A wide container in which the effect of side friction and arching descends to about zero; like the box used by Lee, et al [2]
- A thin model container confined by two plane vertical walls as the container was applied in the present experiments and similarly was used by Andrawes, et al [7] as an example (with the thickness of 30 cm compared with other dimensions of 90 and 200 cm in their tests).

However, in such conditions, where the problem of side friction becomes a matter of importance, the effect of side friction and arching should be considered in the analyses and computations.

The friction between the sand and glass has been so far discussed in relevant literatures; among them is the technical paper by Butterfield, et al [8] where they described the results of their laboratory tests in determining the friction between sand and some other materials like steel, glass, and perspex. According to their experiments, the measured friction angle between the sand and glass (which depends on the sand porosity) are as follows:

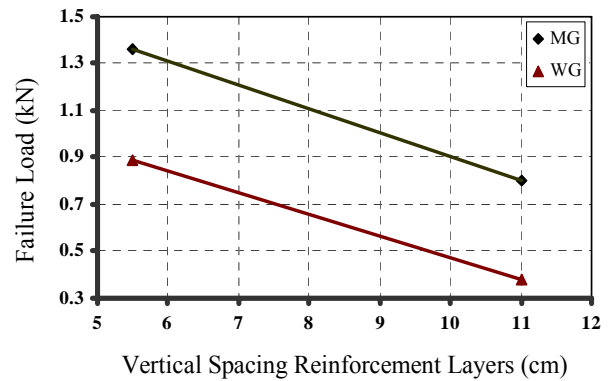

Figure 4. Decreasing the final failure load with increasing the vertical spacing of the reinforcement layers.

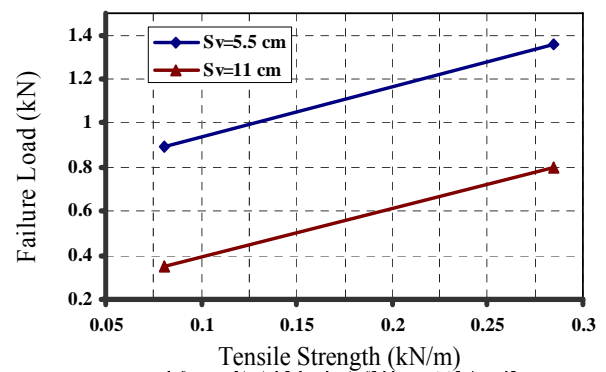

Figure 5. Increasing the final failure load with increasing the tensile strength of the reinforcement layers.

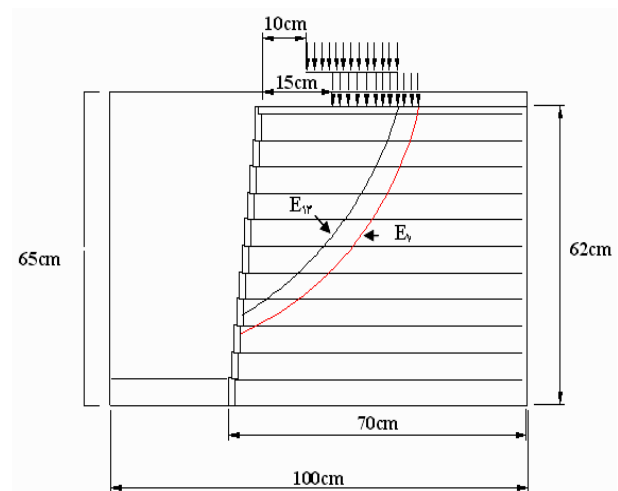

Figure 6. Schematic of reinforced soil layers and the loading.

- For the static conditions (initiation of movement) 12.8 degree for dense sand (n = 35.7 %) and 7.7 degree for loose sand (n = 43.7 %)
- For the kinematics conditions (during the movement) 11.4 degree for dense sand (n = 35.7 %) and 5.9 degree for loose sand (n = 43.7 %)

In the experiments by Lee, et al [2], the dimensions of the test container were selectively chosen as to minimize the effect of side wall friction and also arching to about 10 % as they mention in their article.

Zornberg, et al [9] also mention that the side friction had not been significant in their centrifuge tests.

In the present study, in order to measure the side friction and probably to reduce it, in an experiment, a side walls was lubricated. For this purpose a special cover of membrane pieces was used on the inner side of each glass walls. This membrane pieces was lubricated by silicon grease, so that a thin layer of silicon filled between the membrane and the side glass. It was expected that the friction between the membrane and the lubricated glass would be less than the friction between the sand grains and the glass. Nevertheless, a pair of similar tests: one without lubrication (test E1) and another with lubrication (test E1-LU, see Table 2) indicated that there was not any significant differences (even small) between these two tests. In these two tests, the external vertical load on the surface for collapsing the reinforced soil was exactly 1.1 kN for both tests, and strangely a little less for the test without lubrication.

By means of some simple friction tests, the friction angle between the membrane sheet (without the lubrication) and the glass was found to be 22°, while the similar tests for the lubricated membrane showed a measured friction angle as 5°. This test indicated that in the case of loose to medium sand we cannot have any benefits from the lubrication, because the friction between the loose sand and the glass is not more than the lubricated surface. Based on these discussions, the angle of side friction between the soil and the glass is small and can not be reduced any more (for example to zero) by any other materials. However, for the

dense sand the technique of lubrication using silicon and membrane may reduce the friction to some extend.

4. CALCULATIONS AND DISCUSSION

The calculations for analyzing the behavior of the reinforced soil in the failure estate are usually based on the limited equilibrium concept for both the plane slide and the curvilinear slip surface. The cross sections of failure surface in the present tests are clearly two types, i.e.: circular (for strong reinforcement, as shown in Photos No. 1 and 2 and in Figure 6) and planar (for weak reinforcement as shown in Photo No. 3). In addition, in tests without external loading the failure cross section seems to be almost a logarithmic spiral. In most tests which the reinforcement tensile strength was 0.32 kN/m or more, the observed failure surface was coincident with a circular arc, with the measured radius of almost 60 cm. In the tests with weak reinforcements in which the tensile strength was 0.2 kN/m or less, the failure surface was very close to a plane surface with the slope angle of about 45 deg. to the horizontal level.

For the circular slip surface, the modified versions of both Fellenius's and Bishop's formulae (in which the effect of tensile strength of the reinforcement layers and also the effect of side friction are involved) can be used, though applying the Fellenius formula implies some unknown approximations. Nevertheless, Zornberg, et al [9] have used the modified form of Fellenius formula in which they considered the effect of tensile strength of reinforcement elements for analyzing the results of their centrifuge tests.

In order to modify the mentioned formulae for the conditions of the present tests, it is necessary to include other affecting factors (rather than the tensile strength of reinforcements), i.e. the effect of external load, and the effect of side wall friction.

As shown in Figure 7, the external surface load (Q) corresponding to the failure, should be taken into account in 3 parts:

- As a vertical load along the weight of slices, which has two components, i.e. normal and shear;

- The horizontal thrust on the vertical facing of the wall, which may be considered as a very small effect because of reinforcements;
- The lateral effect of this load on the vertical surface of the side glass walls which promotes the side friction effects in addition to the effect of the dead weight.

In Figure 7, the vertical section is divided into selected slices in which the total external load (Q) is distributed on top of the slices to be Q_i for each slice. The first step of modification of Fellenius's and Bishop's formulae is to take into account the effect of tensile strength and the external load while the effect of side wall friction is ignored. These modified formulae for computing the safety factor (FS_F and FS_B) are respectively:

Modified Fellenius:

$$FS_F = \frac{R \sum \left[(W_i + Q_i) \cdot \cos \alpha_i \cdot \text{tg} \varphi \right] + \sum T_j \cdot Y_j}{R \sum \left[(W_i + Q_i) \cdot \sin \alpha_i \right]} \quad (1)$$

Modified Bishop:

$$FS_B = \frac{R \sum \left[\frac{(W_i + Q_i) \cdot \text{tg} \varphi}{\cos \alpha_i + (\sin \alpha_i \cdot \text{tg} \varphi) / FS_B} \right] + \sum \frac{T_j \cdot Y_j}{FS_B}}{R \sum \left[(W_i + Q_i) \cdot \sin \alpha_i \right]} \quad (2)$$

The terms and the characteristics in the above formulae are defined as follows:

$$F_S = M_r / M_{\text{disturb}}$$

$M_r = R \cdot (\sum N_i) \tan \varphi + M_T$; sum of resisting moment

$M_{\text{disturb}} = R \cdot \sum T_i$; sum of disturbing moment

$M_T = \sum (T_j \cdot Y_j)$; total resistant moment due to the tensile strength of reinforcement

$$W_i = b_i \cdot h_i \cdot \gamma$$

$$\sin \alpha_i = (x + \sum b_i - 0.5b_{i-1}) / R$$

R = The radius of the failure circle

T_j = The tensile strength of a layer of reinforcement which is at the vertical distance of Y_j from the circle centre.

Q_i = Effect of external load in each slice

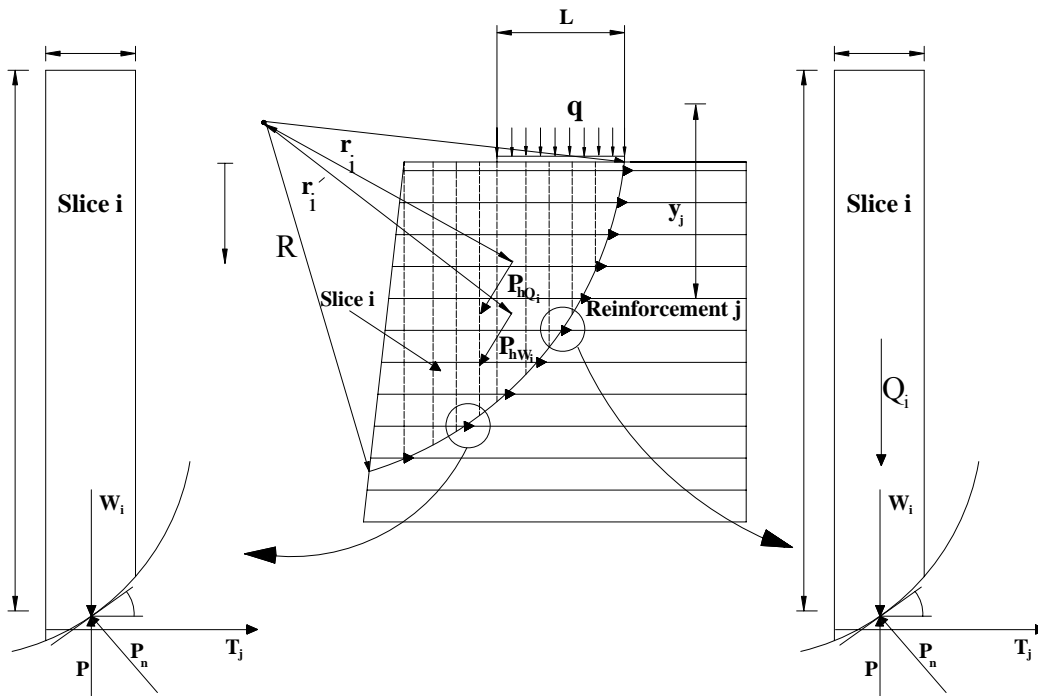

Figure 7. Principal geometrical specifications for analytical computations.

Another way to analyze the experimental results is to have some type of back calculation to find the best compatible parameters. In the present study, we can find the best values for the friction angle of soil at the failure if we solve the equations for $\tan \phi$ for the conditions of $SF = 1$. Accordingly we get:

From modified Fellenius:

$$\tan \phi = \frac{R \sum \left[\left(W_i + Q_i \right) \sin \alpha_i \right] - \sum T_j Y_j}{R \sum \left[\left(W_i + Q_i \right) \cos \alpha_i \right]} \quad (3)$$

From modified Bishop:

$$\tan \phi = \frac{R \sum \left[\left(W_i + Q_i \right) \sin \alpha_i \right] - \sum T_j Y_j}{R \sum \left[\frac{\left(W_i + Q_i \right)}{\left(\sin \alpha_i \cdot \tan \phi \right) + \cos \alpha_i} \right]} \quad (4)$$

For the purpose of considering the effect of side friction in the computations, it is necessary to calculate the effective lateral pressure due to the soil self weight and also from the external applied load. The distribution of the lateral pressure relevant to the applied external load is not as clear as from the self weight of soil. The distribution of these two horizontal pressures on the sections perpendicular to the side wall plane, are respectively uniform (due to the external dead load) and linearly increasing (due to the soil weight). The magnitude of these pressures on the side walls are dependent upon the amount of the coefficient of lateral pressure which is assumed to be $K_o = 1 - \sin \phi$, in the present calculations. The frictional resistance due to the lateral pressure should be taken into account as part of the resistant agents in this type of laboratory model tests. The relevant resistant moment resulted from this frictional resistance is accordingly considered in the calculation of safety factors. For the sake of simplicity of calculations, the moment arm corresponding to the effect of the external load is assumed to be the radius (r_i) passing through the point of mid height of each slice, while the moment arm of the friction effects due to the self

weight of each slice is the radius (r'_i) passing through the point of 1/3 of the height from the base, as shown in Figure 7.

In order to calculate the effect of external load within the soil body, an approximate method of transmitting the vertical surface load through the base of slices is to distribute the whole surface load inside the soil medium (downward) within a region of pseudo-pyramid shape with the side slopes of 1.5 V/1H. Furthermore, because the distribution of the load on any given horizontal plane is not uniform, so it can be accepted to take another approximation for this distribution which is usually taken as a Gaussian pattern.

Considering the above described assumptions, the further modification to the formulae 1 and 2 is made by adding two other terms as: M_{isy} and M_{isq} which are the influence of the side friction resistance due to the weight of the soil and the external load respectively. Therefore, the dominator of the relationships 1 and 2 is extended as:

$$M_T = R \cdot \sum \left[\left(W_i + Q_i \right) \cos \alpha_i \right] \tan \phi + M_{side} + M_T$$

Where

$$M_{side} = 2 \left[\sum M_{isy} + \sum M_{isq} \right],$$

$$M_{isy} = \left(0.5 K_o \cdot \gamma \cdot h_i^2 \cdot \tan \delta \right) \cdot r'_i = F_{whi} \cdot r'_i$$

$$M_{isq} = \left(q \cdot b_i \cdot h_i \cdot K_o \cdot \tan \delta \right) \cdot r_i = F_{Qi} \cdot r_i$$

- δ Angle of friction between soil and the side walls
- h_i The height of each vertical slice
- r_i Radius corresponding to the mid height of the slice
- r'_i Radius corresponding to the 1/3 of the height of slice

The back calculating formulae according to the above modifications (considering the side wall friction) are respectively as follows:

Modified formula 3:

$$\tan \phi = \frac{R \sum \left[\left(W_i + Q_i \right) \sin \alpha_i \right] - \sum T_j Y_j - \sum 2F_{whi} \cdot r'_i - \sum 2F_{Qi} \cdot r_i}{R \sum \left[\left(W_i + Q_i \right) \cos \alpha_i \right]}$$

Modified formula 4:

$$\text{tg}\phi = R \frac{\sum (W_i + Q_i) \sin \alpha_i - \sum T_j Y_j - \sum 2F_{Wh_i} \cdot r_i - \sum 2F_{Qh_i} \cdot r_i}{\sum \left[\frac{(W_i + Q_i)}{(\sin \alpha_i \cdot \text{tg}\phi) + \cos \alpha_i} \right]}$$

A computer program was written in Mat-lab computing language for analyzing the results. Although the formula is quite accurate and straight forward, but there are some ambiguities for the exact values of some of the variables involved. The main one are as follows:

- The internal friction angle of soil is dependent on the confined pressure, and it decreases as the overall pressure increases. For example, Juran, et al [5] reported this effect as the variation of ϕ values from 47 degrees to 35 degrees (for a dense sand) as a result of increasing the confining pressure from very low pressure to a pressure as much as 60 kPa. Similar results were presented for the case of loose sand in their paper. In the present experiments, the external loads apply a pressure as much as 20 to 50 kPa at the failure.
 - Precise values of the load transmitting to the base of each slice are not accurately known. Also, the exact values of friction effect on the side walls are not clearly known, because the effect of distribution of gravity loads (due to the weight of soil) and from the applied external load are not clear.
 - The values of tensile strength of reinforcement layers can be estimated within + -10 %. In order to find the most suitable values, (even with all these uncertainties) several computations with different assumptions were made and their final results were classified. Based on these computations, two types of graphs could be prepared regarding the evaluation of the safety factor:
- ❖ Graphs showing the factor of safety as a

function of the given range of soil friction angle and selected values of tensile strength of reinforcement layers as shown in Figure 8.

- ❖ Graphs showing the values of soil friction angle and the tensile strength of reinforcement layers corresponding to the amount of unity for the safety factor as shown in Figure 9.

Four different assumptions were examined from which the differences between Fellenius's and Bishop's methods (formulae 1 and 2) can be seen, as well as the effect of considering the side wall friction (formulae 3 and 4).

Figure 8 shows the variation of the computed values of safety factor using Bishop's method for two assumptions:

- * Without considering the side wall friction,
- * With considering the side friction both for the test case E1 (see Table 3).

It is obviously known (as can be seen in the present analyses) that the results from Fellenius method are rather conservative because of the assumed simplifications in this method, so the completed results of Fellenius are not referred to here though another type of comparative illustration is shown in Figure 9.

The results of Bishop's method are discussed rather in details. The selected range of friction angle is the range of common values of friction angle (30 to 43 deg.) for the medium to dense sand and the chosen range of tensile strength of reinforcement layers is between 0.2 to 0.42 kN/m. These graphs show that nearly for all cases, an increase of 0.1 kN/m of the reinforcement strength is equivalent to 3 to 4 degrees of soil friction angle. This fact can be followed on a given horizontal line (i.e. constant safety factor line) which crosses the lines of equal tensile strength along increasing the friction angle. Comparing parts a and b of the same figure indicates that if the side wall friction is not taken into account, the strength of soil should be increased about 5 to 8 degrees to reach a coincidence of both safety factor and a given tensile strength of reinforcement elements. Because in reality, the side friction exists, so the analyses should rely on the corresponding facts showed in Figure 8b.

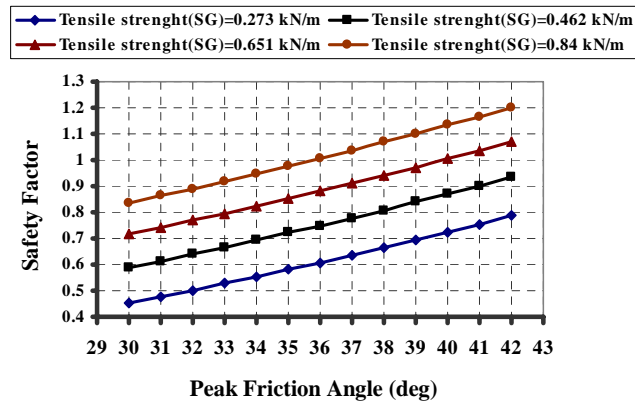

(a)

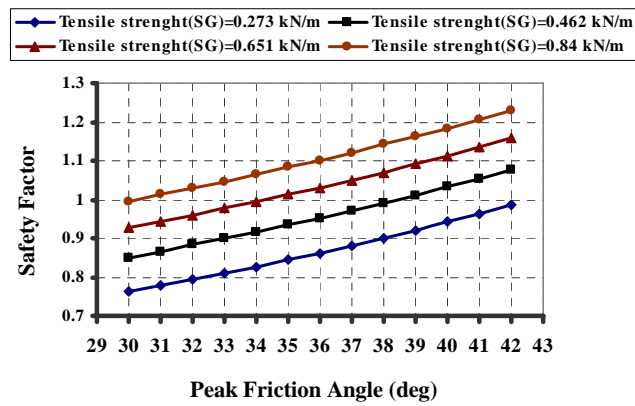

(b)

Figure 8. Variation of safety factor as a function of soil friction angle and the tensile strength of the paper sheets (as reinforcement layers) using Bishop's method for two cases: (a) without considering the side wall friction, (b) with considering the side wall friction.

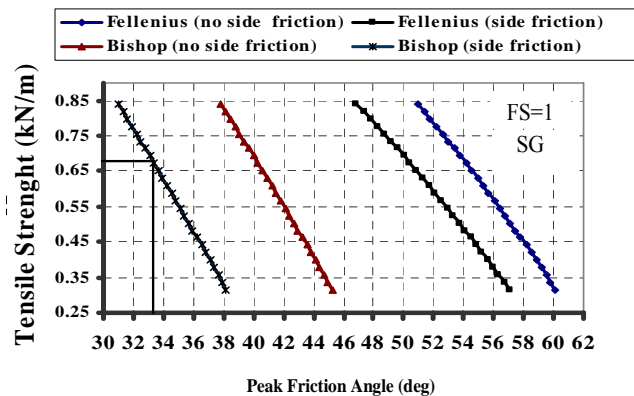

Figure 9. Variation of tensile strength of reinforcement and friction angle of soil for the safety factor of unity.

In Figure 9, the results of both methods of Fellenius and Bishop for both cases (with or without considering the side friction) are illustrated, all values are for the amount of unity for the safety factor and one single point is highlighted. It can be accepted well that the best reliable values are those calculated by Bishop's method with side wall friction. These results also indicate that the procedures of computations and the assumptions can comparatively be accepted as the reliable/or (to some extent) correct values and appropriate analyses.

Because of the dependency of ϕ values upon the applied pressure, the friction angle at the location immediately beneath the loading plate (at the top of failure surface at which the pressure is about 45 to 60 kPa) is rather smaller than its value at the bottom of failure surface (where the pressure is from the self weight and is about 10 kPa). On the other hand, the amount of friction angle which can be read from a given graph (e.g. Figure 9) for $FS_B = 1$ related to an appropriate value of T_j , is found to be quite reliable and acceptable because this amount is nearly equal to the average value of ϕ along the failure surface. These types of computations carried out for most tests, from which similar compatibility could be seen. The values of friction angle found from these computations are compatible to the peak values (compared to the residual values) found from the current experiments.

5. CONCLUSION

Some laboratory experiments were performed to observe the behavior (particularly the failure conditions) of steeped reinforced sandy soil slopes in small scale laboratory model under the plane strain conditions. Reinforcements were made by a non-woven low strength cotton papers and the loading on the soil surface was done by step-wise increments of dead weights. By this small model, the effect of tensile strength of reinforcement elements and their vertical spacing, also the effect of promoting different parts of the embankment on the stability of the embankment are among the subjects which have been studied. A computational program has also been compiled in Matlab, in

order to check the analytical interpretations of the results. The effect of the external loading and the tensile strength of reinforcement elements have been added to the well known formulae of Fellenius and Bishop by which the stability and the relevant amounts of safety factor were analyzed.

Based on the present study, the following remarks could be concluded:

- Failure conditions (i.e. the failure surface and the maximum tolerable load) obtained from the tests, show excellent compatibility between the test results and the logical expectable behavior. The results indicated that the cross section of the failure surface is quite close to a circular arc in the cases corresponding to the external loads for relatively strong reinforcement, whilst almost a straight line for the weak reinforcement, and a logarithmic spiral for the failures related to the self weight of soil.
- Increasing the reinforcement tensile strength, or increasing the number of reinforcing layers, also increasing the strength of the reinforcement, or promoting the reinforcements in the middle height of the slope, and/or increasing the distance of loading from the edge, are the main affecting parameters which can increase the amounts of tolerable external loads.
- The effect of side wall friction can be evaluated almost exactly, for analyzing the stability computations in laboratory scale model tests.
- Simplified Bishop's limit equilibrium formula is the most reliable equation for the analyses regarding the failure conditions and the factor of safety. Further modification for considering the effect of tensile strength of reinforcement and the side wall friction in model tests resulted in excellent compatible and acceptable results.
- It is reliable to accept that the peak friction angle of soil is mobilized during the failure rather than the residual.
- Small model tests can be quite suitable for understanding and interpreting the effect of various affecting parameters in reinforced soil walls if the reinforcing elements are selected from considerably weak materials.

6. REFERENCES

1. Koerner R. M., "Emerging and Future Developments of Selected Geosynthetics Applications (the 32nd Terzaghi Lecture)", *J. of Geotech. and Geoenv. Eng., ASCE*, (2000), 293-306.
2. Lee, K. L., Adams, B. D. and Vagneron, J. M. J., "Reinforced Earth Retaining Walls", *ASCE*, Vol. 99, No. SM10, (1973), 745-764.
3. Porbaha A. and Kobayashi M., "An Investigation of Hazard in Reinforced Embankments", *Geotechnical Hazards*, (1998), 251-258.
4. Zornberg, J. G., Sitar, N. and Mitchell, J. K., "Limit Equilibrium as Basis for Design of Geosynthetic Reinforced Slope", *Journal of Geotechnical and Geoenvironmental Engineering, ASCE*, Vol. 124, No. 8, (August 1998), 684-698.
5. Juran, I. and Christopher, B., "Laboratory Model Study on Geosynthetic Reinforced Soil Retaining Walls", *J. of Geotech. and Geoenv. Eng., ASCE*, Vol. 115, No. 5, (1988), 905-926.
6. Zornberg, J. G. and Arriaga, F., "Reinforced Soil Design: Integration of Digital Image Analysis", Numerical Modeling and Limit Equilibrium, Technical Report, Colorado Advanced Software Institute, Colorado, U.S.A., (2000), 135.
7. Andrawes, K. Z. and McGown, A., "Stereophotogrammetric Measurements of the Kinematics within Plane Strain Model of Reinforced Embankment", Chapter 7 of *Developments in Soil Mechanics and Found. Engineering*", Edit. Banerjee, P. K. and Butterfield, R., Elsevier, Applied Science Publishers, London and New York, (1985), 231-261.
8. Butterfield, R. and Andrawes, K. Z., "On the Angles of Friction Between Sand and Plane Surfaces", *Journal of Terramechanics*, Vol. 8, No. 4, (1972), 15-23.
9. Zornberg, J. G., Sitar, N. and Mitchell, J. K., "Performance of Geosynthetic Reinforced Slopes at Failure", *J. of Geotech. and Geoenv. Eng., ASCE*, Vol. 124, No. 8, (August 1998), 670-683.