

HIGH SPEED FULL SWING CURRENT MODE BICMOS LOGICAL OPERATORS

Arash Ghorbannia Delavar

*Islamic Azad University, Science and Research Branch
Computer Engineering, Shahid Beheshti University
P.O. Box 14515/775, Tehran, Iran
ghorbannia@sr.iau.ac.ir*

Keivan Navi and Omid Hashemipour*

*Department of Electrical and Computer Engineering, Shahid Beheshti University
P.O. Box 14515/775, Tehran, Iran
navi@sbu.ac.ir - hashemipour@sbu.ac.ir*

*Corresponding Author

(Received: October 19, 2006 – Accepted in Revised Form: September 13, 2007)

Abstract In this paper the design of a new high-speed current mode BiCMOS logic circuits is proposed. By altering the threshold detector circuit of the conventional current mode logic circuits and applying the multiple value logic (MVL) approach the number of transistors in basic logic operators are significantly reduced and hence a reduction of chip area and power dissipation as well as an increase in speed is achieved. Simulation with HSpice using BSIM 3V3 model and experimental 65nm BiCMOS technology were carried out for speed, and power consumption considerations at different supply voltage levels. Finally the performance of the proposed circuit is compared to an 8 bit voltage mode adder.

Keywords BiCMOS, Multiple Valued Logics, Low Voltage, Threshold Detector

چکیده در این مقاله، مدارات منطقی سریع مد جریان با استفاده از تکنولوژی BiCMOS ارائه شده است. با اعمال روش های ساده و کارآمد، تعداد ترانزیستورها کاهش یافته و بدین وسیله کاهش چشمگیری در توان مصرفی و مساحت تراشه و همچنین افزایش سرعت به دست آمده است. با شبیه سازی متعدد 65 نانومتری نیز منبع تغذیه نسبت به سطوح ولتاژ کاهش یافته و در پایان کارایی مدارات مد جریان افزایش داده شده و با جمع کننده 8 Bit مد ولتاژ نیز مقایسه شده است.

1. INTRODUCTION

In the early 1970s, NMOS technology was the most feasible, and dominant digital VLSI technology. It retained its status until the late 1970s where a gradual switch to CMOS technology was observed. Memories and microprocessors were widely fabricated using CMOS technology. In the mid- 1980s, the need for higher speed resulted in the introduction of BiCMOS technology as an alternative to CMOS in some applications. The high drive capability of BiCMOS circuits was the main attraction compared to the cheap CMOS alternative. Many high-speed BiCMOS circuits have been fabricated

and published in the VLSI literature [1-3]. Reduction in supply voltage, need for further speed improvement, and the ongoing challenge for reduction of chip area resulted in the introduction of a new family of current mode logic gates [4-7]. In many logic circuits, current mode operation seems to be a serious alternative to voltage mode ones. Literature review of VLSI journals in many instances shows the improvement in terms of speed and the number of transistors used in the current mode logic circuits [1-7]. A major drawback of these circuits is the low drive capability of these devices when applied to large capacitive loads. Current mode circuits demonstrate low performance in this case.

In part 2 the MVL current mode circuits are introduced and their benefits are explained and shown. In part 3, current mode circuits and their difference with voltage mode circuits and the principal of threshold detectors are described. Finally, in part 4 the actual proposed current mode circuit is illustrated and comparative simulation results are presented.

2. MVL CURRENT MODE CIRCUITS

MVL is a potential and actual alternative to Binary logic [8-10]. In MVL, instead of having a digit set comprising {0,1} in radix 2, one can define any other greater digit set for example {0,1,2} in radix 3 or as another example {-2,-1,0,1,2} in radix 4. The MVL circuits are generally operated in two modes of voltage or current.

In the current mode the algebraic sum is done linearly by KCL law, it is enough to connect any arbitrary number of wires and in the connecting node one can obtain the algebraic sum of input currents. This property leads to some very efficient circuits. The threshold detector (TD) circuit is an important decision making part of the MVL current mode circuit. The TD can be implemented by a Greater than (G_i) and less than (L_i) function as described below:

$$X^j \in (0, 1), X \in (0,1,2,\dots,m-1)$$

$$X^j = 1 \text{ IF } X = j, X^j = 0 \text{ IF } X \neq j$$

$$G_j, L_j \in (0,1), X \in (0,1,2,\dots,m-1)$$

$$G_j(x) = 1 \text{ IF } X > j \text{ else } = 0$$

$$L_j(x) = 1 \text{ IF } X \leq j \text{ else } = 0$$

Based on previous work [4-10] and the simulation results presented, as shown in Figure 1 it can be generally concluded that, changing the ratio of $(W/L)_{pu}$ to $(W/L)_{pd}$ in CMOS inverter gates and using a PMOS transistor as a current source or NMOS as current sink, voltage can be converted to current by applying threshold detector circuits.

0.065 μm BiCMOS technology has been used here. Table 1 illustrates its related parameters.

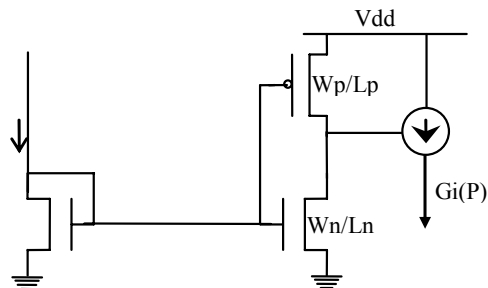

Figure 1. G_i circuit realization.

TABLE 1. 0.065 μm Technology Parameters.

NPN		
	Ft (GHz)	55
	Fmax (GHz)	110
	Gm/Gce @We-min	1200
CMOS		
	Vdd (V)	3.3/1
	Lmin (nm)	65
Resistors	Rs (ohm/sq)	100
Capacitor	C (fF/mm ²)	3
Routing	# Layers	6
Top Metal	Thickness (μm)	2.5

The functions of the threshold detectors are to differentiate between different levels of current and hence multi levels of logic can be specified. Figure 1 also demonstrates the realization of G_i functions. The output of this detector is connected to a PMOS transistor gate for converting the output voltage to the current.

Tables 2a through 2c specify the different required W/L ratios of transistors for specified current levels.

Tables 3a to 3c show the delay in applying G_0 to G_2 .

Tables 3a to 3c show the delay of G_0 to G_2 represented in Figure 1. The observed delay measurement demonstrates that worst case scenario the delay is equal to 0.37ns and at best it is equal to 0.065 ns.

TABLE 2a. Sample of Detector for Threshold Level 0.

	Threshold 0-1	Threshold 1-2	Threshold 2-3
W_n/L_n	0.065 / 0.065	0.065 / 0.065	0.065 / 0.0975
W_p/L_p	0.065 / 0.065	0.065 / 0.065	0.065 / 0.065
Threshold current	10 μ A	30 μ A	50 μ A

TABLE 2b. Sample of Detector for Threshold Level 1.

	Threshold 0-1	Threshold 1-2	Threshold 2-3
W_n/L_n	0.065 / 0.065	0.0975 / 0.065	0.065 / 0.065
W_p/L_p	0.065 / 0.0975	0.065 / 0.0975	0.39 / 0.065
Threshold current	21 μ A	40 μ A	62 μ A

TABLE 2c. Sample of Detector for Threshold Level 2.

	Threshold 0-1	Threshold 1-2	Threshold 2-3
W_n/L_n	0.0975 / 0.0975	0.0975 / 0.065	0.065 / 0.065
W_p/L_p	0.065 / 0.13	0.195 / 0.065	0.0.2925 / 0.065
Threshold current	10 μ A	19 μ A	29 μ A

3. CURRENT MODE CMOS CIRCUITS

In voltage mode logic circuits, the amount of voltage represents a logic level. Current quantities may also be used to represent a logic level [2,3,6]. The main advantage of current mode CMOS circuits over the voltage mode is that the summation in current mode requires no extra elements. That is wires with different current levels

TABLE 3a. Testing Delay Circuits for Level 0.

Test Circuit	Tdr (Rising Edges)	Tdf (Fanning Edges)
G0	0.21 ns	0.1 ns
G1	0.17 ns	0.23 ns
G2	0.2 ns	0.37 ns

TABLE 3b. Testing Delay Circuits for Level 1.

Test Circuit	Tdr (Rising Edges)	Tdf (Fanning Edges)
G0	0.14 ns	0.13 ns
G1	0.09 ns	0.09 ns
G2	0.09 ns	0.18 ns

TABLE 3c. Testing Delay Circuits for Level 2.

Test Circuit	Tdr (Rising Edges)	Tdf (Fanning Edges)
G0	0.22 ns	0.065 ns
G1	0.11 ns	0.13 ns
G2	0.08 ns	0.13 ns

can be connected to the same output node, resulting in an output current which is the algebraic sum of these currents whereas in voltage mode, short circuit of the outputs in CMOS circuits must be avoided.

The current mode circuits are more sensitive to noise. With the trend in technology and reduction in power consumption, it requires a complete circuit change in order to compensate for noise related problems. This rarely happens in a voltage mode circuit, and with following the λ design rules due to manufacturer instructions major changes are not needed.

Operating with current mode has many advantages for example the direction of the current can be used to show the sign, eliminating the necessity of using additional bits to show the sign. Another interesting feature in current mode circuits is the ability of creating various circuits by changing only the threshold detector transistors dimensions and sometimes by increasing or decreasing the number of inputs solely. In current mode every bit has its own sign which is an important feature of this mode.

Figure 2, shows the basic circuit for various current mode logic circuits such as: 2-input AND, 3-input AND,...N-input AND, also 2-input OR, 3-input OR,...n-input OR and other necessary logic circuits such as majority function.

I_{in} , can be a factor of the unit current, this means it can represent the logic two, three, four, etc [1,4,5]. For simplicity, I_{in} can be broken down into different inputs. e.g. 2 or 3 or ... n inputs with unit current instead of one I_{in} with various currents.

The implementation of AND/OR gates are shown in Figure 3. The algebraic sum of two input currents I_{n1} , I_{n2} is done by M1 transistor. The threshold detector unit is shown as an inverter labeled as TD. Changes from high to low happen whenever the algebraic sum of inputs becomes more than the logic 0.5, this activates the PMOS transistor, which results in having an OR gate. An AND gate is achieved if the converter is set to change when the algebraic sum of inputs become the logic 1.5.

Table 4 represents the true table of a two input AND gate as well as a two input OR gate. It is important to observe that none of these two gates respond to logical 0.5 as illustrated in Table 4. This is due to the noise immunity of the circuit which is achieved by applying the exact ratio (W/L) of the pull up to pull down transistors.

The implementation of Equation 1 which is called the Majority function is shown in Figure 4.

$$I_{n1}I_{n2} + I_{n1}I_{n3} + I_{n2}I_{n3} \quad (1)$$

The above capabilities in current mode circuits and the reduction of the number of transistors are very important and crucial in microchip areas and power managements. As can be observed, the uniform structure of these designed circuits, easily

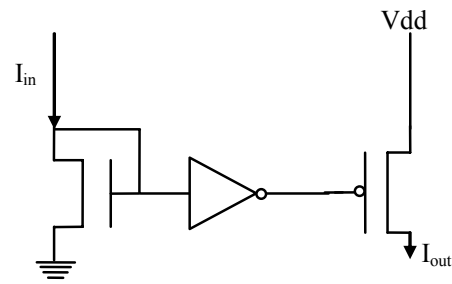

Figure 2. Basic current mode circuit for different logical functions.

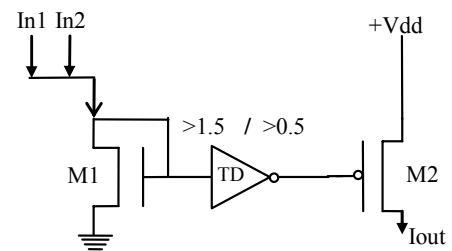

Figure 3. Implementation of current mode double input AND/OR gates.

TABLE 4. Truth Table of Two Input AND/OR Gates.

Σ_{in}	Gates		Input Current	Output Current	
	OR ₂	AND ₂		OR ₂	AND ₂
0	0	0	0	0	0
0.5	0	0	10 μ A	0	0
1	1	0	20 μ A	20 μ A	0
2	1	1	40 μ A	20 μ A	20 μ A

allows the designer to increase the number of inputs, while in the voltage mode, this is only possible with an increased number of transistors. For instance multiple input OR gates are formed by increasing the number of inputs connected to the drain of transistor M1 as shown in Figure 5. Since the input to the circuit is an aluminum or Polysilicon system; this allows the designer to freely assign the number of inputs to the system. In

fact no physical change to the circuit in Figure 3 is needed and in fact the designer can submit the same circuit to the chip manufacturer [1-3].

The actual summation of currents is slightly different with the expected value, and sometimes unexpectedly, from the summation of the two currents of logic 1, logic 2 is not obtained. This error increases as the number of inputs increase, although it causes no error since the OR circuit will change its output condition as soon as it detects the first logic one. In the case of logic zero, fortunately leakage currents are so small that they can be ignored. Table 5 shows the accuracy of the n-input OR circuit. For $n > 2$ the loss applied by leakage of the algebraic sum of the input increases.

As mentioned, the threshold detector changes its output condition as soon as detecting the first logic 1 in its input. The error in logic zero is so small that it does not concede for analysis. The value for the threshold detector has been defined as logic 0.5, which is $10 \mu\text{A}$. The error from zero to input 7 that is practically used is less than $1.5 \mu\text{A}$. This can be totally ignored.

4. DESIGN OF FULL SWING CURRENT MODE BICMOS CIRCUITS

To understand the behavior of the current mode BiCMOS circuits a brief discussion of conventional voltage mode BiCMOS digital circuits makes sense [1]. CMOS technology provides performance superior to NMOS and bipolar technologies in power dissipation, noise margins, packing density and the ability to integrate large complex functions with high yield. As the name “BiCMOS” implies, it is a combination of Bipolar and CMOS technologies. The bipolar technology is used for high switching speed, high driving capability and good noise performance. But CMOS technology ensures low power dissipation, high noise margin and high packing density. Figure 6 shows the conventional BiCMOS inverter.

When input is equal to logical zero, the transistor MP1 is ON and transistors MN1 and MN2 are off, so the Bipolar transistor Q1 is ON. As the voltage at the base of Q1 is equal to logical 1 then MN2 is ON hence, Q2 is off. These facts lead to logical “1” in

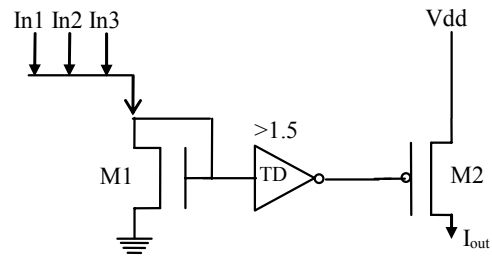

Figure 4. Current mode Majority function.

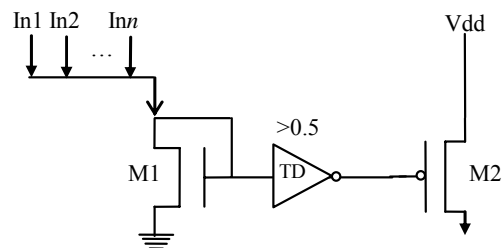

Figure 5. N-input realization of OR gate.

TABLE 5. Truth Table of N-Input OR.

Σ_{in}	OR_n	Input Current	Output Current
0	0	0 + Error (0)	0
1	1	$20 \mu\text{A}$	$20 \mu\text{A}$
2	1	$40 \mu\text{A}$	$20 \mu\text{A}$
3	1	$60 \mu\text{A}$	$20 \mu\text{A}$
\vdots	\vdots	\vdots	\vdots
n	1	$n*20\text{-Error}(n)$	$20 \mu\text{A}$

output. If the input is equal to logical “1”, all the transistors states will be inverted which results in a logical “0” in the output. Any arbitrary circuit can be implemented using BiCMOS conventional technologies. For example Figure 7 demonstrates an 8-input NAND gate.

Clearly, as shown in Figure 7 increasing the number of inputs increases the number of

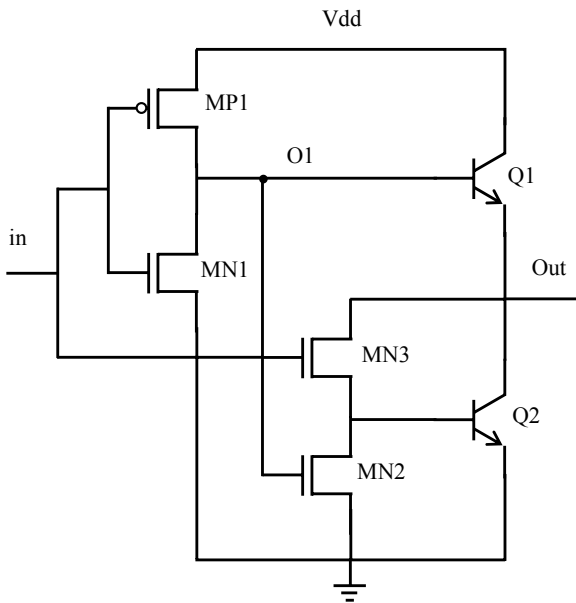

Figure 6. Conventional BiCMOS Inverter.

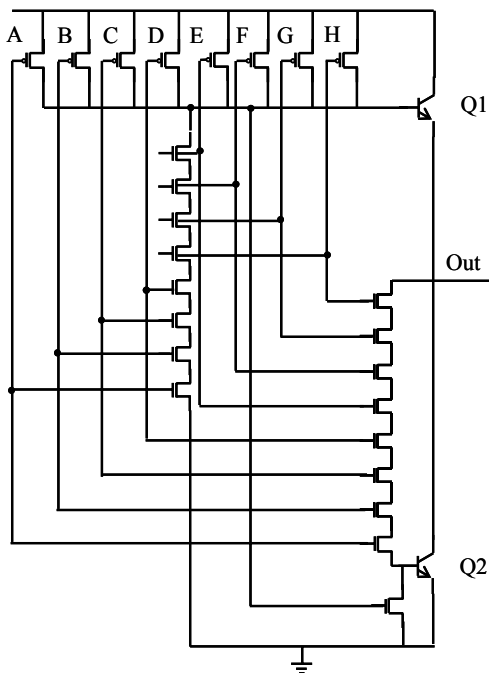

Figure 7. An 8-input NAND gate.

transistors. Using current mode BiCMOS circuits, will show that the number of transistors will not increase, with an increase in the number of inputs.

Figure 8 Shows a 2-input XOR circuit with $TD > 1$. If the algebraic sum of In_1 and In_2 is greater than logic 1.5, then the output of the threshold detector changes its state. If the algebraic sum of inputs equals zero, there is no current at the output. If the sum of these inputs is one 1, since the output of TD is high, the M3 transistor is on and input current is copied through current mirror (M1, M2), finally the input current is exactly copied in the output. This means that the logic one at the output will be obtained.

When the sum of two inputs is greater than logic 1.5, in other words when two inputs are logic one, then the output of threshold detector changes its state and becomes Low. M3 transistor switches off and no current will be copied into the output. Table 6 shows the accuracy of 2-input XOR.

As mentioned previously using a combination of one TD, one NMOS input transistor and a PMOS output transistor, different circuits, such as multi-input OR, multi-input AND, Majority circuit can be developed. It is important to drive the current rapidly. Based on previous investigation, the best choice is the utilization of BiCMOS circuits [16].

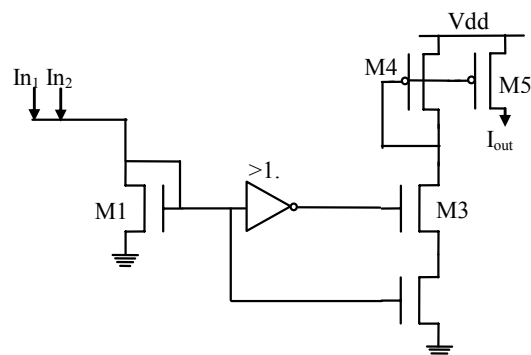

Figure 8. The circuit diagram of a 2-input XOR gate.

TABLE 6. Truth Table of 2-Input XOR.

Σ_{in}	XOR ₂	Input Current	Output Current
0	0	0	0
1	1	20 μ A	20 μ A
2	0	40 μ A	0

used in different voltage and current mode BiCMOS circuits.

Table 8, compares the area of different current and voltage mode gates and also the percentage of improvement in speed.

The difference between this circuit and the 2- Figure 11 3 input XOR is that, if the input is higher

than logic 2.5, again a current of logic one is applied to the system by M1 transistor ($TD > 1.5$). The problem with this circuit is the presence of many current mirrors that slow down the system performance. Table 9 shows the truth table of this circuit.

The improved circuit of the previous 3-input

TABLE 8. Area Comparison of the Voltage Verses Proposed Current Mode BiCMOS Circuits.

Technology Circuit	Current Mode BiCMOS (μm^2)	Voltage Mode BiCMOS (μm^2)	Speedup Percent
2-input NOR	0.684	0.779	% 12
⋮	⋮	⋮	⋮
n-input NOR	0.684	$0.513 + 0.133 (n)$	% $100_{n \rightarrow \infty}$
2-input NAND	0.699	0.779	%10
⋮	⋮	⋮	⋮
n-input NAND	$0.668 + 0.016 (n)$	$0.513 + 0.133 (n)$	% $88_{n \rightarrow \infty}$
2-input XOR	0.453	0.912	% 50
3-input XOR	1.13	1.311	% 13

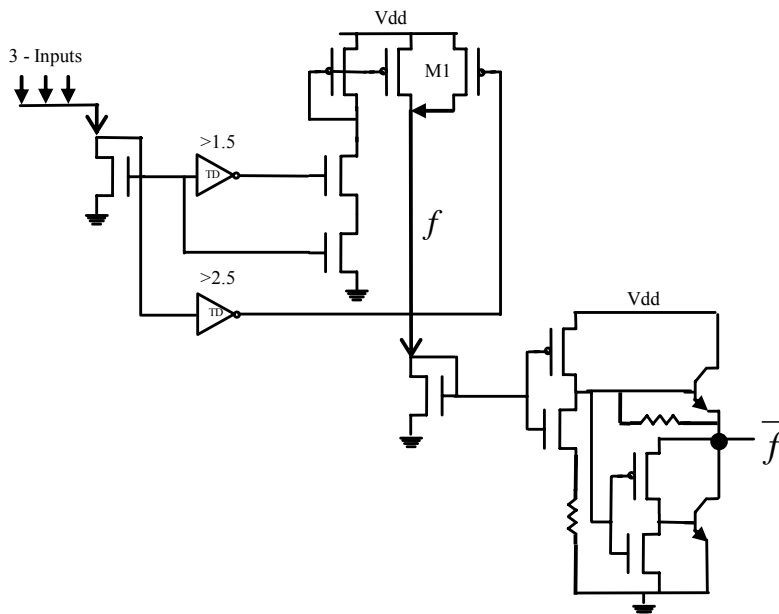

Figure 11. Current mode BiCMOS, 3-input XOR.

XOR Gate using the new logic is shown in Figure 12.

In the above design, two current mirrors and a CMOS inverter gate are eliminated, resulting in a considerable reduction in delay. It should be noted that (W/L) of the M1 transistor is a lot less than (W/L) of M2 transistor, because in the case of $\sum in = 1$, the current passing through M2 is equal to a logic 1 (20 μA). But in the case of $\sum in = 3$ it is obvious that the maximum current which passes through M2 transistor will be 3 times the logic 1, and this current must be limited in some way. This problem can be eliminated by the decreasing (W/L) of M1 transistor. In actual circuits if voltage mode BiCMOS design is used in a digital system, it is not necessary to decrement this current, since the output voltage is always equal to $V_{dd} - V_{be}$. Figure 13 shows the effect of variation of resistance values on rise and fall time of the proposed logic circuits. Table 10 compares the speed improvement, in different voltage mode BiCMOS logics with proposed current mode BiCMOS circuits.

The variation of power supply voltage and its effect on rise time and fall time is shown in Figure 14.

The delay improvement of an 8-bit full adder, as shown in Figure 15 can be compared in voltage and proposed current mode as presented in Table 11.

6. CONCLUSION

In this work the operation of available current mode CMOS logic gates are verified and a new generation of multi-valued current mode BiCMOS logic is presented. When applying high capacitive loads these circuits are much faster than the similar BiCMOS voltage mode. In regard to multi-inputs NOR and multi-inputs NAND, compared to their equivalent voltage mode circuits, increase in speed is 17 % and 6 % in the best and worst cases respectively. In logic gates, under the worst conditions one MOS transistor and under the best conditions 2n-3 MOS transistors are eliminated. Unlike the voltage mode, applying the proposed design to multiple input NOR and NAND gates, will result in no increase in the number of MOS transistors used in the circuit.

TABLE 9. Truth Table of the Current Mode BiCMOS, 3-Input XOR Gate.

Input Logic	Input Current	Current f	Logic \bar{f}
0	0	0	1
1	20 μA	20 μA	0
2	40 μA	0	1
3	60 μA	20 μA	0

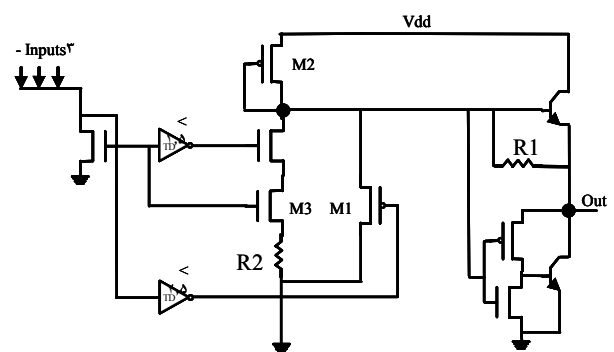

Figure 12. The improved circuit of 3-input XOR.

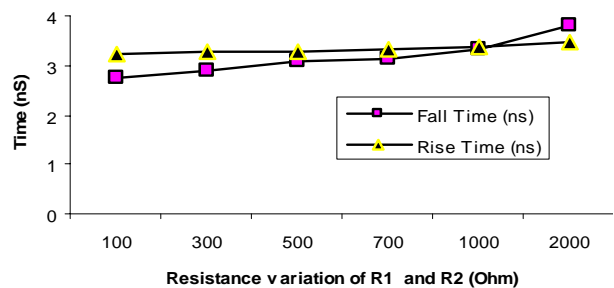

Figure 13. Rise and fall time changes versus variation in resistance R1 and R2.

TABLE 10. Speed Increase in Proposed Current Mode Compared to Voltage Mode.

Circuit	NOR	NAND	XOR
Maximum Speedup	% 15	% 14	% 6
Minimum Speedup	% 12	% 13	% 17

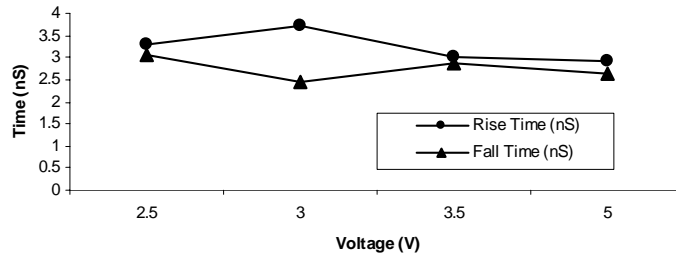

Figure 14. Rise and fall time changes versus power supply variation.

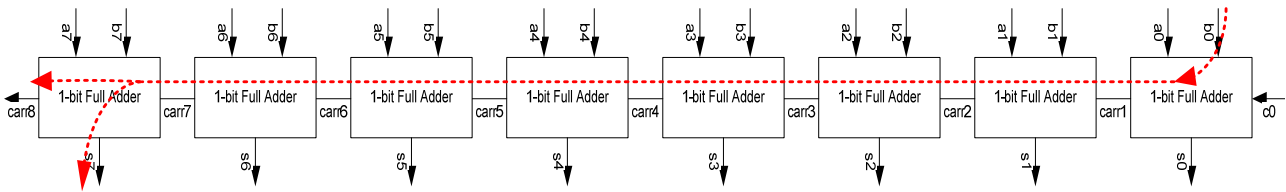

Figure 15. Simulated 8-bit ripple adder.

TABLE 11. Simulation Results (8-Bit FA) @ $C_{load}=1pF$

Circuit	Delay (nm)	Improvement %
8-Bit RCA FA, Voltage-Mode	61.3	72
8-Bit RCA FA, Proposed Circuits	17.0	

7. REFERENCES

- Navi, K., Kazemi parsa, M. and Ghorbannia Delavar, A., "Very high speed current mode logical circuits", *The CSI Journal of Computer Science and Engineering*, (Spring 2005), 45-50.
- Chen, C.-L., "2.5 μm BiCMOS Technology", *IEEE Journal of Solid-State Circuits*, Vol. 27, No. 4, (April 1992).
- Garg, A., Chan Carusone, A. and Voinigescu, S., "A 1-Tap 40-Gbps Look-ahead Decision Feedback Equalizer in 0.18 μm SiGe BiCMOS Technology", *IEEE Journal of Solid-State Circuits*, (October 2006), 2224-2232.
- Navi, K., Kazeminejad, A. and Etienneble, D., "Performance of CMOS Current Mode Full Adders", *IEEE Proc. Int'l. Symp. Multiple Valued Logic*, (May 1994), 27-34.
- Navi, K. and Etienneble, D., "From Multi-Valued Current Mode CMOS Circuits to Efficient Voltage Mode CMOS Arithmetic Operators", *IEEE Proc. Int'l. Symp. Multiple Valued Logic*, (May 1995), 58-64.
- Arfaee, A. and Navi, K., Kazemi Parsa, M. and Akbari, A., "Design of High Speed 2's Complement MAC Unit Using Redundant Number System", *6th Annual Computer Society of Iran Computer Conf.*, Esfahan, (2001), 53-58
- Kazeminejad, A., Navi, K. and Etienneble, D., "CML Current Mode Full Adders for 2.5-V Power Supply", *IEEE Proc. Int'l. Symp. Multiple Valued Logic*, (May 1994), 10-15.
- Temel, T., Morgül, A., "Implementation of Multi-Valued Logic Gates Using Full Current Mode CMOS Circuits", *Analog Integrated Circuits and Signal Processing*, KAP, Vol. 39, No. 2, (2004), 191-204.
- Temel, T., "Current-mode CMOS Design of Multi-Valued Logic Circuits", PhD Thesis, Bogazici University, Department of Electrical and Electronics Engineering, (2002).
- Morgul, A. and Turgay, T., "A New Level Restoration Circuit for Multi-valued Logic", *Proc. of IEEE ISCAS'04*, Vancouver, CA, (May 2004), 649-652.