

SOME GEOMETRICAL BASES FOR INCREMENTAL-ITERATIVE METHODS

M. Rezaiee-Pajand*, M. Tatar and B. Moghaddasie

Department of Civil Engineering, Ferdowsi University of Mashhad
P.O. Box 91775-1111, Mashhad, Iran

mrpajand@yahoo.com – razhan_tatar@yahoo.com - behrang_m_xyz@yahoo.com

*Corresponding Author

(Received: December 29, 2008 – Accepted in Revised Form: July 2, 2009)

Abstract Finding the equilibrium path by non-linear structural analysis is one of the most important subjects in structural engineering. In this way, Incremental-Iterative methods are extremely used. This paper introduces several factors in incremental steps. In addition, it suggests some control criteria for the iterative part of the non-linear analysis. These techniques are based on the geometric of equilibrium path. Finally, some examples illustrate the capabilities of suggested approaches.

Keywords Non-Linear Analysis, Incremental-Iterative Method, Control Method

چکیده یافتن مسیر ایستایی با تحلیل غیرخطی، یکی از مهم ترین هدفها در مهندسی سازه است. برای این کار، روش های نموی-تکراری بسیاری استفاده شده است. این مقاله، عامل های گوناگونی را برای گام نموی معرفی می کند. همچنین، برای قسمت تکراری تحلیل غیرخطی، شماری از راه کارهای کنترلی پیشنهاد می شود. این روش ها براساس هندسه مسیر ایستایی بنا شده اند. در پایان، چندین نمونه عددی برای نشان دادن توانایی راه کارهای پیشنهادی عرضه می شود.

1. INTRODUCTION

Incremental-iterative methods are able to perform non-linear analysis for structural problems. These approaches can trace the equilibrium path by predictor and corrector steps. Most of the iterative techniques follow the classical Newton-Raphson procedure with some modifications. In this method, load factor remains constant during iterations. This makes the analysis divergent when it faces the limit points on the equilibrium path. In order to solve the mentioned problem, other criteria have been examined, such as displacement [1], work [2,3], residual energy [4], orthogonality [5] and so on. In this way, the comparison of various techniques could reveal the advantages and disadvantages of presented approaches [6,7].

One of the most applicable techniques is the Arc-Length Method. In 1979, Riks introduced the constant arc-length which could pass the limit and

turning points [8]. Subsequently, Crisfield modified Riks' approach and established the cylindrical arc-length method [9,10]. Afterwards, Fujii and Ramm investigated the path switching for bifurcation points in equilibrium paths [11]. For more simplification, the linearization techniques (e.g. orthogonality [5]) can be applied.

On the other hand, the incremental part plays an important role in analysis convergence. Selecting suitable parameters in predictor steps, could make an excessive impression on the rate of convergence, specially in highly non-linear problems [12,13]. For example, a proper extrapolation in the incremental part can avoid divergence [14,15]. Incremental-iterative techniques, as a solution of non-linear problems, are also able to combine with Neural Networks, Boundary Element Method and Normal Flow Algorithm [16-18].

This paper aims to suggest some geometrical parameters to modify the corrector part of

incremental-iterative solution. Furthermore, several incremental factors are examined to obtain the compatibility between suggested techniques and incremental parameters. Section 2 describes the incremental-iterative procedure. Afterwards, various formulations for the corrector load factor are suggested in Section 3. The state of predictor step is shown in Section 4. Finally, a number of numerical examples are provided to evaluate the suggested methods.

2. THE INCREMENTAL-ITERATIVE METHOD

In this section, the structure of incremental-iterative analysis will be reviewed. As it is observed in Figure 1, the n th increment starts at equilibrium point $(n-1)$.

First iterative point can be achieved by linearization:

$$K^{n-1} \Delta u_1^n = \Delta \lambda_1^n P \quad (1)$$

Where, K^{n-1} is the tangent stiffness matrix at $(n-1)$, Δu represents the incremental displacement, $\Delta \lambda$ shows the incremental load factor and P is the external load vector. Superscripts and subscripts

indicate the number of increment and iteration, respectively. After each increment, iterative process begins. At this stage, $\delta \lambda_i^n$ and δu_i^n , corrector load and displacement factors, are calculated and improve the incremental factors:

$$\Delta \lambda_{i+1}^n = \Delta \lambda_i^n + \delta \lambda_i^n \quad (2)$$

$$\Delta u_{i+1}^n = \Delta u_i^n + \delta u_i^n \quad (3)$$

In order to compute δu_i^n , the following linear problem should be solved:

$$K_i^n \delta u_i^n = r_i^n \quad (4)$$

where, r_i^n is the decreased residual force, and can be obtained by

$$r_i^n = \tilde{r}_i^n + \delta \lambda_i^n P \quad (5)$$

In this equation, \tilde{r}_i^n represents a residual force vector. By substituting Equation 5 into (4), δu_i^n can be computed as follows:

$$\delta u_i^n = \delta u_i^{*n} + \delta \lambda_i^n \delta u_i^{*n} \quad (6)$$

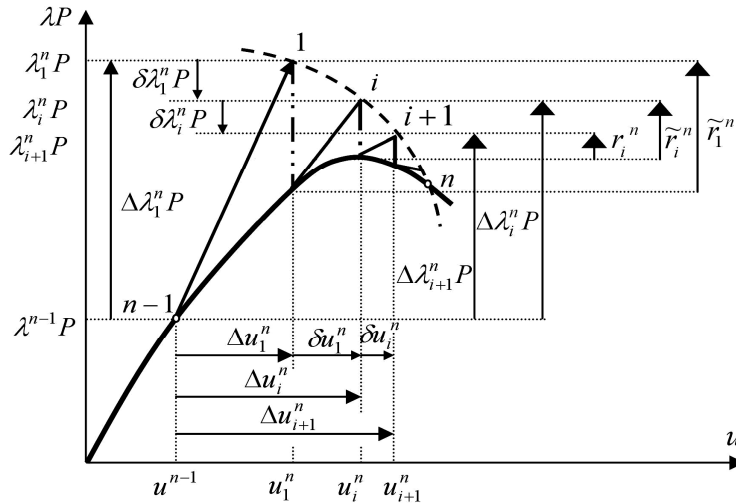

Figure 1. The structure of incremental-iterative method.

Here, $\delta u_i^{\prime n}$ and δu_i^n have been produced by the residual force and external load, respectively:

$$K_i^n \delta u_i^{\prime n} = \tilde{f}_i^n \quad (7)$$

$$K_i^n \delta u_i^n = P \quad (8)$$

Equations 7 and 8 have no answers when the n th increment is located so close to a critical point. In order to overcome this problem, a coefficient should be considered beside the increment factor.

As it is observed, another equation is needed to estimate $\delta \lambda_i^n$ and complete the non-linear analysis process. It is needless to say that using a proper equation can have a great effect on the rate of convergence. There are many methods based on various assumptions to obtain a formula for $\delta \lambda_i^n$. Most of these approaches have been extracted from the geometry of the load-displacement diagram. In 1981, Crisfield introduced one of the most reliable techniques in computation of the corrector load factor. He assumed that the length of Δu_{i+1}^n is constant for all iterations in each increment and it equals to the initial value L_n [9]:

$$(L_n)^2 = \Delta u_1^n T \Delta u_1^n \quad (9)$$

$$\Delta u_{i+1}^n T \Delta u_{i+1}^n = (L_n)^2 \quad (10)$$

After substituting Equations 3 and 6 into (10), $\delta \lambda_i^n$ can be computed by solving Equation 11:

$$a(\delta \lambda_i^n)^2 + b(\delta \lambda_i^n) + c = 0 \quad (11)$$

$$a = \delta u_i^{\prime n T} \delta u_i^{\prime n} \quad (12)$$

$$b = 2(\Delta u_i^n + \delta u_i^{\prime n}) T \delta u_i^{\prime n} \quad (13)$$

$$c = (\Delta u_i^n + \delta u_i^{\prime n}) T (\Delta u_i^n + \delta u_i^{\prime n}) - (L_n)^2 \quad (14)$$

The mentioned approach is called The Cylindrical Arc-Length Method [9]. Because of simplicity in computer programming and adequate reliability,

this technique is excessively used in non-linear analyses.

3. ESTIMATION OF THE CORRECTOR LOAD FACTOR

There are many methods to procure a suitable formula for $\delta \lambda_i^n$. This section suggests some techniques which can be applied for highly non-linear problems.

3.1. Linearization of Arc-Length Method

The cylindrical arc-length method leads to a second order Equation 10. It can cause some problems when one of two answers is selected. To avoid this, Equation 10 is replaced by the following equation:

$$\Delta u_i^n T (\Delta u_1^n + \delta u_i^n) = (L_n)^2 \quad (15)$$

Where, L_n is obtained by using Equation 9. Considering Equation 6, $\delta \lambda_i^n$ is available by a linear equation:

$$\delta \lambda_i^n = \frac{(L_n)^2 - \Delta u_i^n T (\Delta u_1^n + \delta u_i^{\prime n})}{\Delta u_i^n T \delta u_i^{\prime n}} \quad (16)$$

3.2. Orthogonality of Δu_i^n and δu_i^n One of the assumptions, that can lead to a simple formula for a corrector load factor, is to make an orthogonal condition between Δu_i^n and δu_i^n :

$$\Delta u_i^n T \delta u_i^n = 0 \quad (17)$$

By applying Equation 6, the value of $\delta \lambda_i^n$ will be in hand:

$$\delta \lambda_i^n = -\frac{\Delta u_i^n T \delta u_i^{\prime n}}{\Delta u_i^n T \delta u_i^{\prime n}} \quad (18)$$

3.3. Minimizing Residual Length Another parameter, which can be useful in non-linear

analysis, is the residual length shown by S_i^n in each iteration. It is defined by summation of δu_i^n and r_i^n :

$$S_i^n = \delta u_i^n + r_i^n \quad (19)$$

Minimizing the value of the residual length is one of the techniques that results in a suitable formula for $\delta \lambda_i^n$:

$$\frac{\partial}{\partial \lambda} (S_i^n)^T S_i^n = 0 \quad (20)$$

By substituting Equations 5, 6 and 19 into (20), the corrector load factor will be obtained:

$$\delta \lambda_i^n = - \frac{(\delta u_i^n + \tilde{r}_i^n)^T (\delta u_i^n + P)}{(\delta u_i^n + P)^T (\delta u_i^n + P)} \quad (21)$$

It is noteworthy that the load and the displacement have been divided by the length of the relative vectors at the first Predictor Step. Consequently, Equation 20 is dimensionless.

3.4. Minimizing the Residual Area The residual

area (or the residual energy) is an applicable parameter in estimation of the corrector load factor during non-linear analysis. This factor is a product of decreased residual force and corrector displacement factor. Minimizing the residual area (the area abcd in Figure 2) can be a proper criterion for iterative part of the analysis:

$$\frac{\partial}{\partial \lambda} (r_i^n)^T \delta u_i^n = 0 \quad (22)$$

By applying Equations 5 and 6, $\delta \lambda_i^n$ is achieved:

$$\delta \lambda_i^n = - \frac{P^T \delta u_i^n + \tilde{r}_i^n^T \delta u_i^n}{2P^T \delta u_i^n} \quad (23)$$

3.5. Minimizing Residual Perimeter Another practical parameter is the residual perimeter. In fact, this factor is the perimeter of the residual area in Figure 2. Similar to the previous approach, minimizing the perimeter leads to a suitable formula for the corrector load factor:

$$\frac{\partial}{\partial \lambda} (2\delta u_i^n)^T \delta u_i^n + 2r_i^n^T r_i^n = 0 \quad (24)$$

Similar to Section 3.3, Equation 24 is dimensionless.

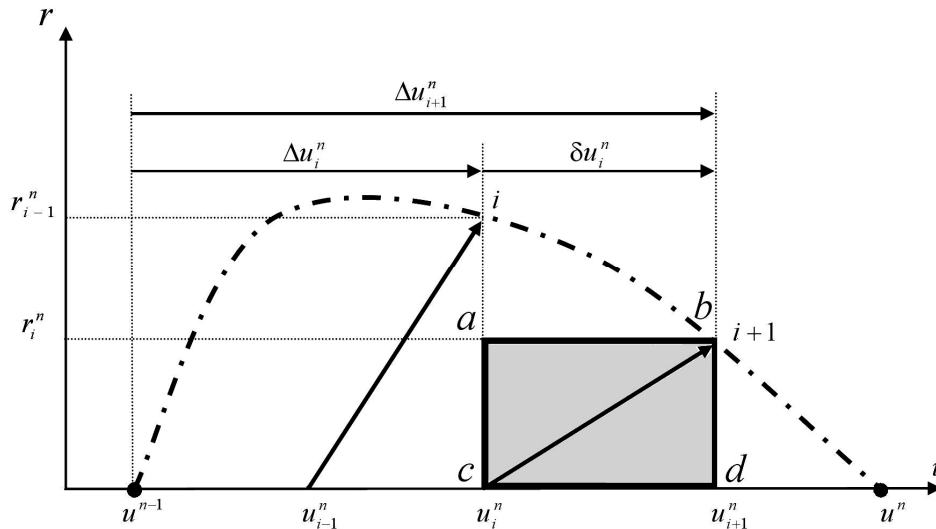

Figure 2. Residual load-displacement diagram.

By considering Equations 5 and 6, $\delta\lambda_i^n$ will be obtained:

$$\delta\lambda_i^n = -\frac{\delta u_i'^n T \delta u_i'^n + \tilde{f}_i^n T P}{\delta u_i'^n T \delta u_i'^n + P^T P} \quad (25)$$

4. PREDICATOR STEP

When the equilibrium point (n-1) is definite, the load incremental factor ($\Delta\lambda_1^n$) should be estimated at the beginning of the next step. There is no need to mention that the increment is directly related to the convergence of the analysis. In other words, if the value of increment were inordinately chosen large or small, the problem would become divergent or the rate of convergence would decrease.

Other incremental parameters can be utilized instead of the load increment. One of them is the length of the equilibrium path and called the length incremental factor (L_n). The value of L_n is dependent on previous length increment (L_{n-1}) [19]:

$$L_n = \pm L_{n-1} \left(\frac{J_D}{J_{n-1}} \right)^{\frac{1}{2}} \quad (26)$$

Where, J_D and J_{n-1} are the number of selected iterations by the analyzer and the number of iterations in the preceding steps, respectively. Therefore, the load incremental factor at predictor step can be achieved by substituting Equation 26 into the following equation:

$$\delta\lambda_i^n = \pm \frac{L_n}{\sqrt{\Delta u_1'^n T \Delta u_1'^n + 2P^T \Delta u_1'^n + P^T P}} \quad (27)$$

Where, $\Delta u_1'^n$ is obtained by solving a linear equation:

$$K^{n-1} \Delta u_1'^n = P \quad (28)$$

The first value of length incremental factor (L_1) depends on the value of load increment at the initial

point ($\Delta\lambda_1^1$):

$$(L_1)^2 = \Delta u_1^1 T \Delta u_1^1 + 2\Delta\lambda_1^1 P^T \Delta u_1^1 + (\Delta\lambda_1^1)^2 P^T P \quad (29)$$

In addition, the constant arc-length and cylindrical arc-length incremental factors (named the perimeter and displacement increments, respectively) have been applied by researchers. If $2\Delta\lambda_1^1 P^T \Delta u_1^1$ in Equation 29 and $2P^T \Delta u_1'^n$ in Equation 27 were omitted, the procedure of perimeter increment would be achieved. Similarly, by neglecting $P^T P$ and $(\Delta\lambda_1^1)^2 P^T P$, displacement incremental factor will be in hand. Another parameter, which is used in non-linear analysis, is the work (area) incremental factor.

5. NUMERICAL EXAMPLES

In this section, some examples are given to evaluate the advantages and disadvantages of the suggested methods. The behavior of the provided structures is highly non-linear (including snap-through and snap-back behaviors) and the analyses have been performed by several incremental factors. By doing this, the effects of incremental parameters on the iterative process can be seen. In the following, four space trusses and a shallow arch are analyzed by the cylindrical arc-length and five suggested methods. In these examples, the effect of material non-linearity is not considered and this paper focuses on geometrically non-linear structures. Each example contains the shape and properties of the structure, load-displacement diagram and a table. Tables give the number of iteration for each method which is related to the incremental factor. The sign of "—" in tables shows that the approach becomes divergent. In addition, the diagrams of load-displacement are based on cylindrical arc-length with displacement increment.

5.1. The Space Truss Many 2D and 3D trusses are investigated in literatures [20,21]. Figure 3 illustrates one of the simplest structures including limit points [22]. This structure has 4 members and 3 degrees of freedom. The properties of the space truss are dimensionless and assumed as follows:

$A = 1$, $E = 100$, $H = 100$, $\gamma = \sqrt{2.375}$, $P = 100$, $\Delta\lambda_1 = 0.2$, $J_D = 2$, $J_{\max} = 10$ and permitted error $\varepsilon_C = 10^{-4}$.

The equilibrium path of the structure includes two limit points (Figure 4). Table 1 reveals that all the suggested techniques have the same iteration number in comparison with the cylindrical arc-

length method for each increment factor. As Table 1 shows, load parameter makes the analysis divergent.

5.2. The Truss Arch As it can be seen, Figure 5 shows a truss arch with 24 members and 21 degrees of freedom [23,18].

In this figure, the values of A , E , H , L , S and W are equal to 317 mm^2 , $3 \times 10^3 \text{ N/mm}^2$, 62.16 mm ,

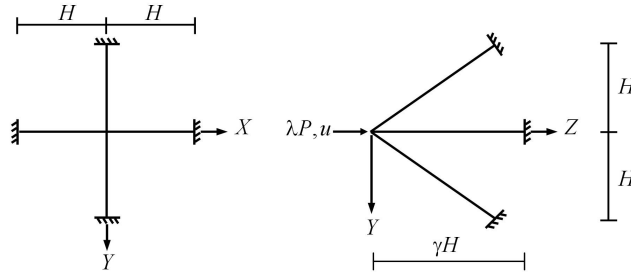

Figure 3. The space truss.

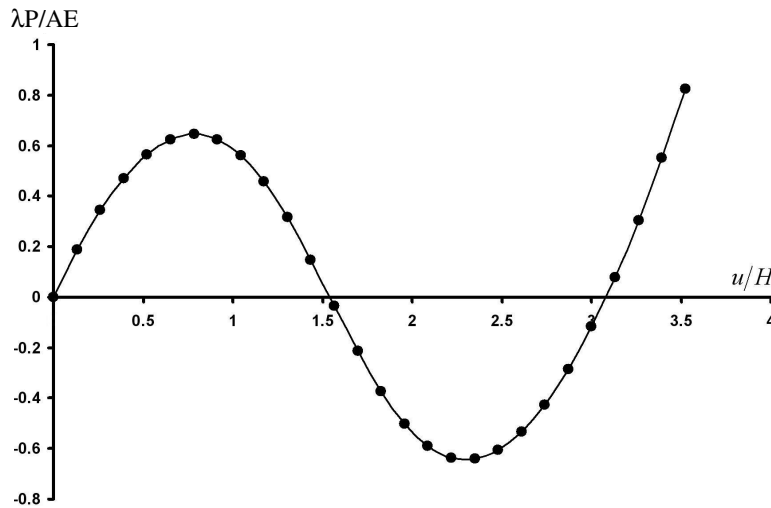

Figure 4. The load-displacement diagram for the space truss.

TABLE 1. The Number of Iterations in the Analysis of the Space Truss.

Method	Incremental Factors				
	Load	Displacement	Length	Perimeter	Area
All Methods	—	54	34	44	36

433 mm, 250 mm and 20 mm, respectively. At the beginning of analysis, P is assumed 150N, $\Delta\lambda_1^1$ is 0.5, J_D equals 5, J_{max} is 15 and ϵ_C is equal to 10^{-4} .

Figure 6 illustrates the load-displacement diagram containing two limit points. Table 2 presents the number of iteration for each approach with several incremental parameters. As it is shown, the displacement factor has almost the least iteration during analysis. Again, the load parameter does not obtain the correct equilibrium path. In this example, Minimizing Residual Length and Minimizing Residual Perimeter converge to the equilibrium point for most of the incremental factors, although the number of iteration has increased.

5.3. The Truss Dome The space truss in Figure 7 has 264 members and 219 degrees of freedom [24]. This structure includes many degrees of freedom. Some characteristics of this truss are: $A = 450 \text{ mm}^2$, $E = 2.1 \times 10^5 \text{ N/mm}^2$, $H = 4580 \text{ mm}$, $P = 15 \times 10^3 \text{ N}$, $\Delta\lambda_1^1 = 0.15$, $J_D = 5$, $J_{max} = 20$ and $\epsilon_C = 10^{-4}$.

The load-displacement diagram, similar to previous examples, contains two limit points (Figure 8). The number of iterations for each method is provided in Table 3. As it can be observed, the displacement factor leads to answer for all mentioned techniques, especially for Cylindrical Arc-Length and Minimizing Residual Area which reach the minimum iteration.

Four suggested methods converge to the equilibrium path with three different incremental factors in similar way.

5.4. The Shallow Truss Dome The structure in Figure 9 has 168 members and 147 degrees of freedom [25,18]. Some characteristics of the shallow truss dome are assumed as follows: $A = 100 \text{ mm}^2$, $E = 10^3 \text{ N/mm}^2$, $H = 1790.22 \text{ mm}$, $P = 1000 \text{ N}$, $\Delta\lambda_1^1 = 0.25$, $J_D = 6$, $J_{max} = 20$ and $\epsilon_C = 10^{-4}$.

Figure 10 illustrates the diagram of the load-displacement. This structure buckles two times during analysis. Table 4 presents the number of iteration for each approach with several incremental factors. Except Minimizing Residual Area method, all techniques trace the equilibrium path with displacement, length and perimeter increments. Cylindrical Arc-Length and Orthogonality of Δu_i^n

and δu_i^n reach the equilibrium path with minimum iteration. Conversely, Linearization of Arc-Length needs the maximum iteration.

5.5. The Shallow Arch The structure shown in Figure 11 has a complicated behavior [6]. The arch is located on a circle arc and divided into 10 elements. The values of A , I , E , H , L and W are dimensionless and equal to 10^4 , 10^8 , 200, 500, 5000 and 200, respectively. At the beginning of analysis, P is 1000, $\Delta\lambda_1^1$ is assumed 0.4, J_D equals 5, J_{max} is 15 and ϵ_C is equal to 10^{-4} .

The equilibrium path of the structure includes two turning points and two limit points. Figure 12 displays the diagrams of load-displacement. Table 5 presents the number of iteration for each technique with several incremental parameters. As it can be seen, the Orthogonality of Δu_i^n and δu_i^n and Minimizing Residual Area are become divergent for all incremental factors. On the other hand, Cylindrical Arc-Length with length incremental factor results in the minimum iteration. Linearization of Arc-Length, Minimizing Residual Length and Minimizing Residual Perimeter act similarly. It is noteworthy that these methods are convergence for a load incremental factor.

6. CONCLUSION

The modification of the incremental-iterative method is an important subject in non-linear analysis. To this aim, many efforts were made to find a fast and reliable solution for different problems. This paper aims to prove that various techniques can be used for iterative part of the non-linear analysis. In addition, the compatibility between incremental factors and iterative methods was discussed by investigating highly non-linear problems. In some cases, a number of provided techniques became divergent which means they need revising. Conversely, other approaches traced the equilibrium path successfully for all numerical examples. In most of the analyses, displacement and perimeter increments led to the reliable answers. On the other hand, the load and area incremental factors make the non-linear analysis divergent.

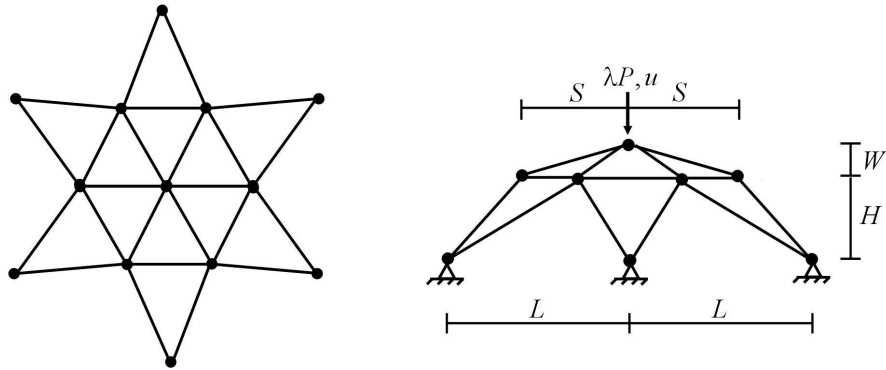

Figure 5. The truss arch.

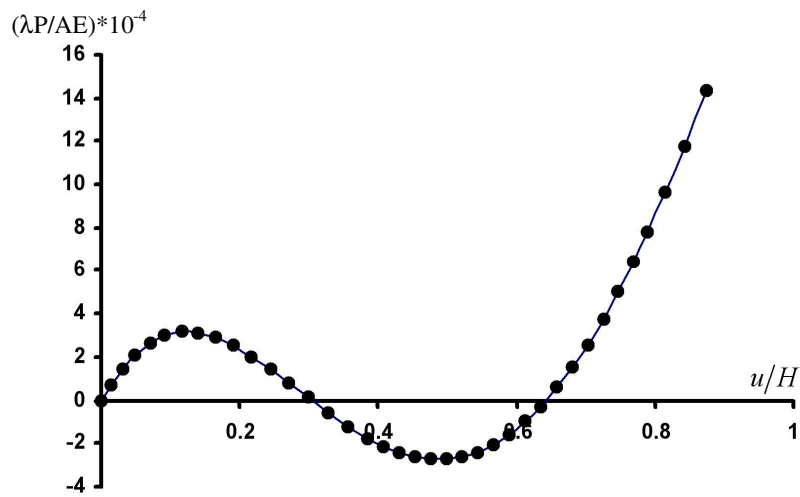

Figure 6. The load-displacement diagram for the truss arch.

TABLE 2. The Number of Iterations in the Analysis of the Truss Arch.

Method	Incremental Factors				
	Load	Displacement	Length	Perimeter	Area
Cylindrical Arc-Length	—	61	—	69	—
Linearization of Arc-Length	—	61	—	74	—
Orthogonality of Δu_i^n and δu_i^n	—	61	—	69	—
Minimizing the Residual Length	—	153	96	100	102
Minimizing the Residual Area	—	66	—	92	—
Minimizing the Residual Perimeter	—	145	96	100	108

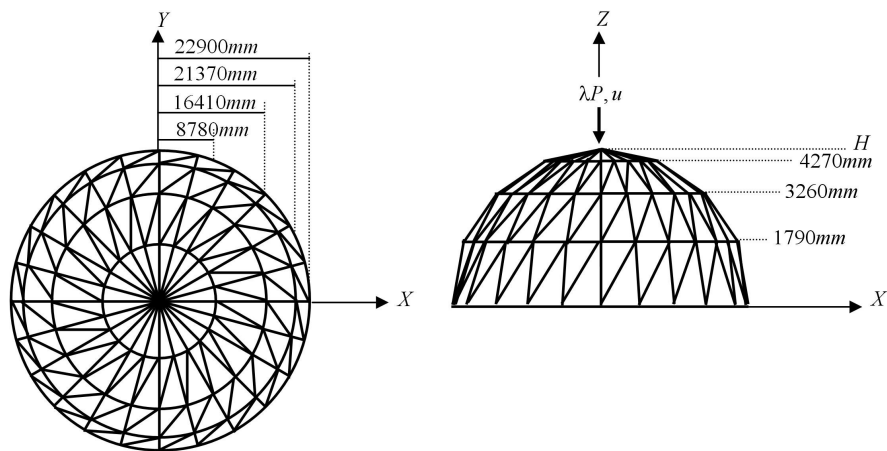

Figure 7. The truss dome.

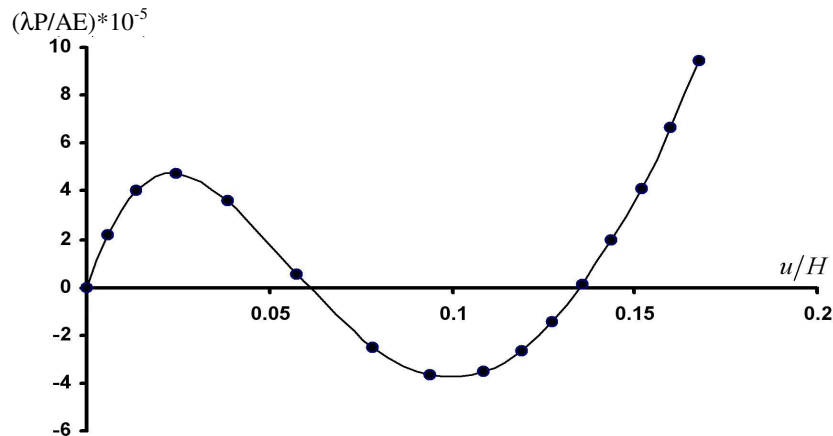

Figure 8. The load-displacement diagram for the truss dome.

TABLE 3. The Number of Iterations in the Analysis of the Truss Dome.

Method	Incremental Factors				
	Load	Displacement	Length	Perimeter	Area
Cylindrical Arc-Length	—	52	—	—	—
Linearization of Arc-Length	—	74	65	64	—
Orthogonality of Δu_1^n and δu_1^n	—	69	93	93	—
Minimizing the Residual Length	—	75	69	69	—
Minimizing the Residual Area	—	52	—	—	—
Minimizing the Residual Perimeter	—	79	69	69	—

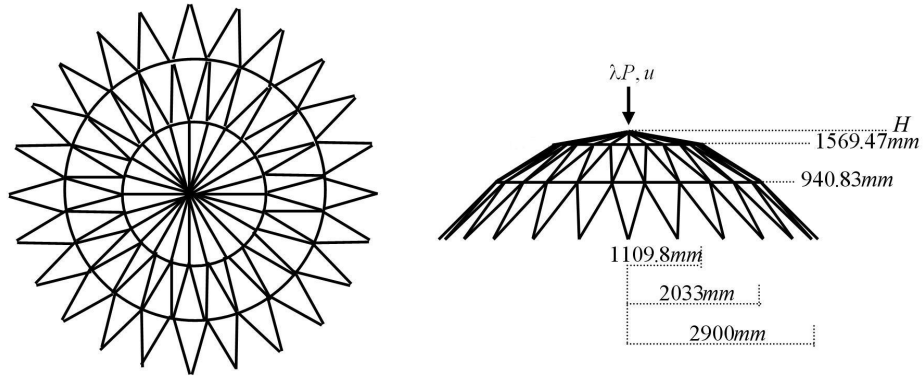

Figure 9. The shallow truss dome.

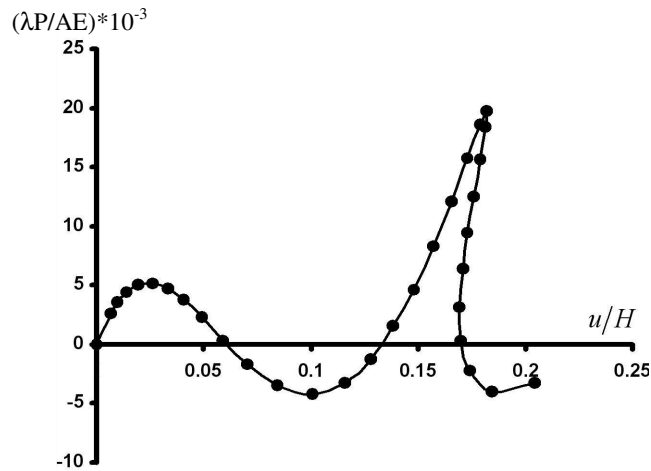

Figure 10. The load-displacement diagram for the shallow truss dome.

TABLE 4. The Number of Iterations in the Analysis of the Shallow Truss Dome.

Method	Incremental Factors				
	Load	Displacement	Length	Perimeter	Area
Cylindrical Arc-Length	—	99	140	152	—
Linearization of Arc-Length	—	244	195	193	—
Orthogonality of Δu_i^n and δu_i^n	—	101	147	141	—
Minimizing the Residual Length	—	116	183	177	—
Minimizing the Residual Area	—	—	—	—	—
Minimizing the Residual Perimeter	—	116	183	176	—

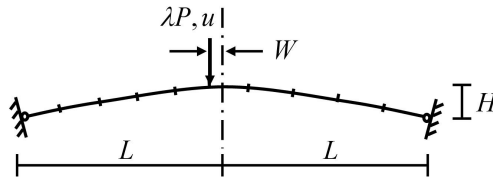

Figure 11. The shallow arch.

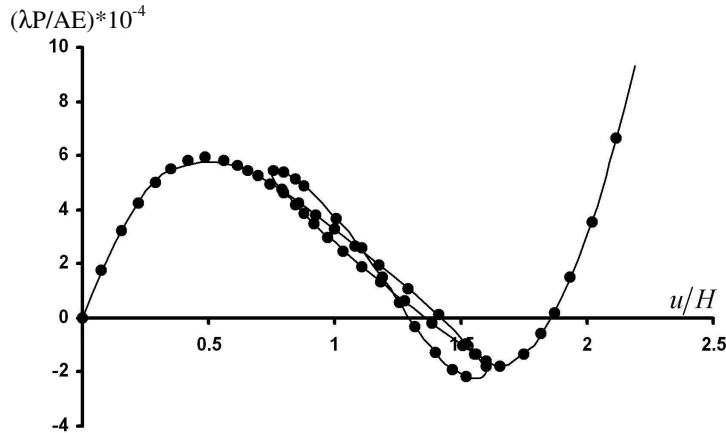

Figure 12. The load-displacement diagram for the shallow arch.

TABLE 5. The Number of Iterations in the Analysis of the Shallow Arch.

Method	Incremental Factors				
	Load	Displacement	Length	Perimeter	Area
Cylindrical Arc-Length	—	240	165	—	378
Linearization of Arc-Length	566	319	340	385	—
Orthogonality of Δu_i^n and δu_i^n	—	—	—	—	—
Minimizing the Residual Length	270	274	290	—	591
Minimizing the Residual Area	—	—	—	—	—
Minimizing the Residual Perimeter	246	289	268	—	—

7. REFERENCES

1. Batoz, J.L. and Dhatt, G., "Incremental Displacement Algorithms for Nonlinear Problems", *Int. J. Numer. Meth. Engng.*, Vol. 14, (1979), 1262-1266.
2. Chen, H. and Blandford, G.E., "Work-Increment-Control Method for Non-Linear Analysis", *Int. J. Numer. Meth. Engng.*, Vol. 36, (1993), 909-930.
3. Lin, T.W., Yang, Y.B. and Shiau, H.T., "A Work Weighted State Vector Control Method for Geometrically

- Nonlinear Analysis”, *Comput. Struct.*, Vol. 46, (1993), 689-694.
4. Widjaja, B.R., “Path-Following Technique Based on Residual Energy Suppression for Nonlinear Finite Element Analysis”, *Comput. Struct.*, Vol. 66, (1998), 201-209.
 5. Forde, B.W.R. and Stiemeier, S.F., “Improved Arc Length Orthogonality Methods for Nonlinear Finite Element Analysis”, *Comput. Struct.*, Vol. 27, (1987), 625-630.
 6. Clarke, M.J. and Hancock, G.J., “A Study of Incremental-Iterative Strategies for Non-Linear Analyses”, *Int. J. Numer. Meth. Engng.*, Vol. 29, (1990), 1365-1391.
 7. Regon, S.A., Gurdal, Z. and Watson, L.T., “A Comparison of Three Algorithms for Tracing Nonlinear Equilibrium Paths of Structural Systems”, *Int. J. Solid Struct.*, Vol. 39, (2002), 689-698.
 8. Riks, E., “An Incremental Approach to the Solution of Snapping and Buckling Problems”, *Int. J. Solid Struct.*, Vol. 15, (1979), 529-551.
 9. Crisfield, M.A., “A Fast Incremental/Iterative Solution Procedure that Handles Snap-Through”, *Comput. Struct.*, Vol. 13, (1981), 55-62.
 10. Bashir-Ahmed, M. and Xiao-Zu, S., “Arc-Length Technique for Nonlinear Finite Element Analysis”, *J. Zhejiang Univ. SCI*, Vol. 5, No. 5, (2004), 618-628.
 11. Fujii, F. and Ramm, E., “Computational Bifurcation Theory: Path-Tracing, Pinpointing and Path-Switching”, *Engng. Struct.*, Vol. 19, No. 5, (1997), 385-392.
 12. Kouhia, R. and Mikkola, M., “Tracing the Equilibrium Path Beyond Simple Critical Points”, *Int. J. Numer. Meth. Engng.*, Vol. 28, (1989), 2923-2941.
 13. Yang, Y.B., Lin, S.P. and Leu, L.J., “Solution Strategy and Rigid Element for Nonlinear Analysis of Elastically Structures Based on Updated Lagrangian Formulation”, *Engng. Struct.*, Vol. 29, (2007), 1189-1200.
 14. Lopez, S., “An Effective Parametrization for Asymptotic Extrapolations”, *Comput. Meth. Appl. Mech. Engng.*, Vol. 189, (2000), 297-311.
 15. Lopez, S., “Geometrically Nonlinear Analysis of Plates and Cylindrical Shells by a Predictor-Corrector Method”, *Comput. Struct.*, Vol. 79, (2001), 1405-1415.
 16. Kim, J.H. and Kim, Y.H., “A Predictor-Corrector Method for Structural Nonlinear Analysis”, *Comput. Meth. Appl. Mech. Engng.*, Vol. 191, (2001), 959-974.
 17. Mallardo, V. and Alessanderi, C., “Arc-Length Procedures with BEM in Physically Nonlinear Problems”, *Engng. Anal. Bound. Elem.*, Vol. 28, (2004), 547-559.
 18. Saffari, H., Fadaee, M.J. and Tabatabaei, R., “Nonlinear Analysis of Space Trusses using Modified Normal Flow Algorithm”, *ASCE J. Struct. Engng.*, Vol. 134, No. 6, (2008), 998-1005.
 19. Bathe, K.J. and Dvorkin, E.N., “On the Automatic Solution of Non-Linear Finite Element Equations”, *Comput. Struct.*, Vol. 17, (1983), 871-879.
 20. Rezaee Pajand, M. and Taghavian Hakkak, M., “Nonlinear Analysis of Truss Structures using Dynamic Relaxation”, *International Journal of Engineering*, Vol. 19, No. 1B, (December 2006), 11-22.
 21. Legaro, S.S. and Valvo, P.S., “Large Displacement Analysis of Elastic Pyramidal Trusses”, *Int. J. Solid Struct.*, Vol. 43, No. 16, (2004), 4867-4887.
 22. Casciaro, R., Salerno, G. and Lanzo, A.D., “Finite Element Asymptotic Analysis of Slender Elastic Structures: A Simple Approach”, *Int. J. Numer. Meth. Engng.*, Vol. 35, (1992), 1397-1426.
 23. Krenk, S., “An Orthogonal Residual Procedure for Non-Linear Finite Element Equations”, *Int. J. Numer. Meth. Engng.*, Vol. 38, (1995), 823-839.
 24. Krishnamoorthy, C.S., Ramesh, G. and Dinesh, K.U., “Post-Buckling Analysis of Structures by Three-Parameter Constrained Solution Techniques”, *Finit. Elem. Anal. Design*, Vol. 22, (1996), 109-142.
 25. Powell, G. and Simons, J., “Improved Iteration Strategy for Nonlinear Structures”, *Int. J. Numer. Meth. Engng.*, Vol. 17, (1981), 1455-1467.