

EXPERIMENTAL INVESTIGATION OF BOILING AND CONDENSATION HEAT TRANSFER OF A TWO PHASE CLOSED THERMOSYPHON

S.H. Noie, M.H. Kalaei and M. Khoshnoodi

*Department of Chemical Engineering, Ferdowsi University of Mashhad
Mashhad, P.O. Box. 9177948944-1111, I.R.Iran
noie@um.ac.ir - kalaeimh@yahoo.com – khosh@hamon.usb.ac.ir*

(Received: April 3, 2004 - Accepted in Revised Form: August 18, 2004)

Abstract In this paper the heat transfer characteristics of a two-phase closed thermosyphon over a wide range of heat transfer rates, system pressure, aspect ratios and filling ratios were studied. The experiments focused on the boiling and condensation heat transfer characteristics of a thermosyphon with a copper tube having 25 and 32 mm inside and outside diameters. Distilled water was used as the working fluid. The experimental boiling and condensation heat transfer coefficients inside the thermosyphon were compared with the existing correlations. A good agreement between the experimental results of condensation heat transfer of the thermosyphon and Nusselt's correlation was obtained. In addition, the optimal working fluid filling and the overall heat transfer coefficient were evaluated for practical operation. Finally, according to poor agreement between the experimental results of boiling heat transfer coefficient and existing correlations, the working conditions were analyzed and a new practical formula (correlation) was presented. The new correlation can be used to predict boiling heat transfer coefficient generally.

Key Words Aspect Ratio, Two-Phase, Closed Thermosyphon, Boiling Heat transfer Coefficient, Condensation Heat Transfer Coefficient

چکیده در این مقاله ویژگی های انتقال حرارت یک ترموسیفون دو فازی بسته در گستره وسیعی از نرخ انتقال حرارت با نسبت ابعاد (A.R) و نسبت پر شدن (F.R) مطالعه شده است. آزمایش ها بیشتر بر ویژگی های انتقال حرارت جوشش و چگالش متمرکز شده است. در این پژوهش از آب به عنوان سیال عامل و از یک لوله مسی با مشخصات OD = 32 mm و ID = 25 mm استفاده شد. ضرایب تجربی انتقال حرارت جوشش و چگالش داخل ترموسیفون با روابط موجود مقایسه شد. مطابقت خوبی بین نتایج تجربی انتقال حرارت چگالش ترموسیفون مورد مطالعه و رابطه ناسلت بدست آمد. علاوه بر این، نسبت بهینه سیال عامل و ضریب کلی انتقال حرارت برای عملیات کاربردی ارزیابی شد. در نهایت به دلیل مطابقت بین نتایج تجربی ضریب انتقال حرارت جوشش و روابط موجود، شرایط عملکرد مورد بررسی قرار گرفت و در نتیجه یک معادله کاربردی جدید ارائه شد. این رابطه به طور معمول می تواند برای پیش بینی ضریب انتقال حرارت در جوشش مورد استفاده قرار گیرد.

1. INTRODUCTION

A two-phase closed thermosyphon is a highly efficient heat transfer device. It employs the principle of evaporation and condensation of the working fluid. It is a closed container filled with a small amount of a working fluid (Figure 1). In such a device, heat is supplied to the evaporator

wall, which causes the liquid in the pool to evaporate. The generated vapor then moves upwards to the condenser. The heat transported is then rejected into the heat sink by a condensation process. The condensate forms a liquid film that flows downwards due to gravity. The thermosyphon has been proved to have a comparatively high heat transfer capability with a

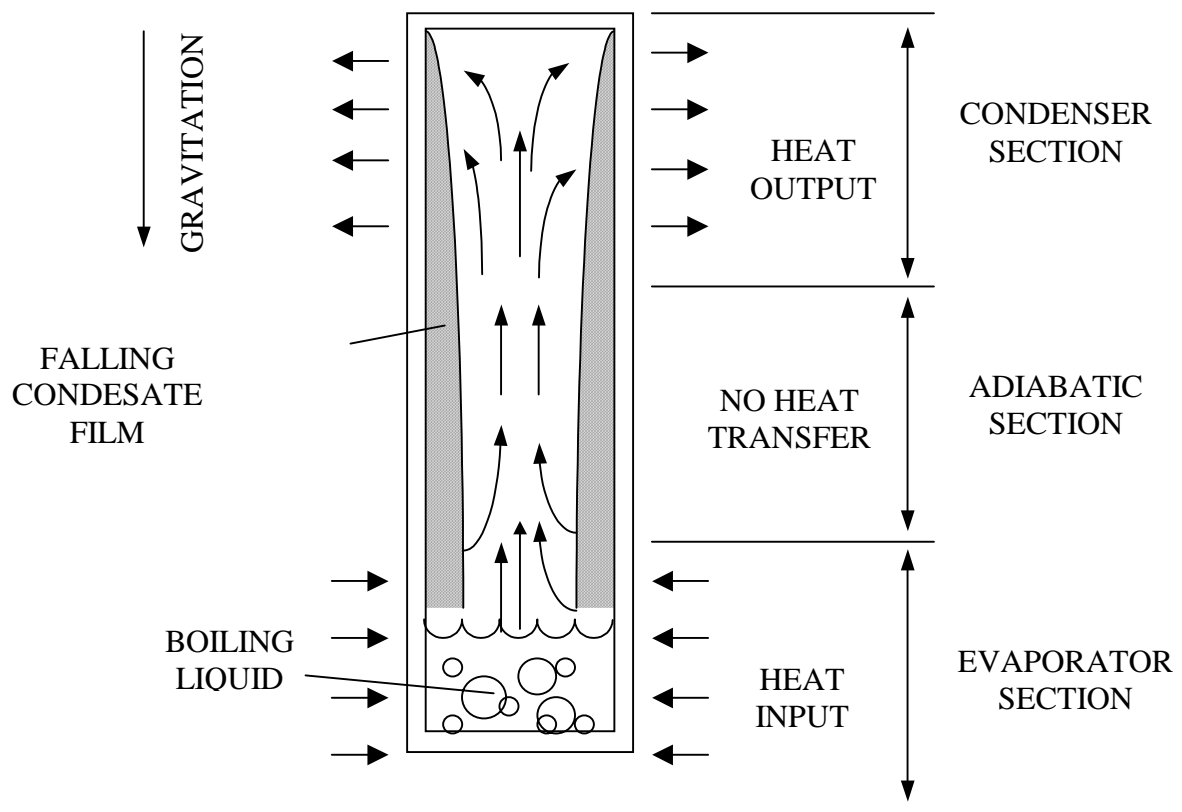

Figure 1. Schematics of a two-phased closed thermosyphon.

very small temperature difference between the heat source and heat sink. Moreover, it is simple and cheap, therefore more attractive to the thermal industry [1].

The two-phase closed thermosyphons are used for construction of thermosyphon heat exchangers. The thermosyphon heat exchangers have extensive applications in energy recovery system in domestic and industry, especially in waste heat recovery from flue gas [2].

Over the past few years, a number of experimental studies have been performed to establish correlations that may be used to calculate the boiling and condensation heat transfer coefficients in a two-phase closed thermosyphon. However, since the thermodynamic behavior of

thermosyphons is quite complicated, additional experiments are required to obtain the coefficients for boiling and condensation heat transfer [3-4].

Additional research on boiling in thermosyphons that focuses on pool boiling in the evaporator section, liquid film boiling and the working principle of the thermosyphon based on its flow pattern, is required, including a good estimate of the boiling heat transfer coefficient. Imura et al. [5] and Shirashi et al. [6] studied heat transfer in the pooling liquid and falling film, as well as the mechanism of flooding in the boiling phenomena independently. Kaminaga et al. [7] proposed an empirical correlation for the boiling heat transfer over a wide range of pressure, heat flux, and filling ratio.

Condensation heat transfer in a two-phase closed thermosyphon has been subject of active analytical study. Some investigations and contributions to this problem have been reported [8-11]. Lee and Bedrossian [12] derived a simple condensation equation that was similar to that of Nusselt's condensation model. However, the characteristics of condensation in the thermosyphon are much more complex than that of Nusselt's condensation model. In particular, the interfacial shear due to countercurrent liquid and vapor flow obstructs the condensation heat transfer.

The analysis of two-phase flow heat transfer in a two phase closed thermosyphon is very complicated and is still required to do some study.

This paper presents an experimental study to find the thermal performance of a two-phase closed thermosyphon by changing various experimental parameters. Heat transfer in boiling and condensation has been investigated for many years and many phenomena have been explained. However, at present it is still difficult to predict heat transfer coefficients with satisfactory accuracy. Therefore, the main objective in the

present paper is to evaluate the actual boiling and condensation heat transfer coefficients of a thermosyphon experimentally. Experimental data of boiling heat transfer are correlated and a new practical correlation for predicting the boiling coefficient is presented.

2. EXPERIMENTAL APPARATUS AND PROCEDURE

A schematic of the experimental apparatus is shown in Figure 2. The main parts of test rig are the test section, a liquid reservoir for charging, an electric heater, cooling water circulation, a high vacuum system, and temperature measurement using a data acquisition system. The thermosyphon is made of a smooth copper tube with an outside diameter of 32 mm and a total length of 98 cm. The condenser section is 38 cm long, while the evaporator and adiabatic section length is variable according to values of the aspect ratio

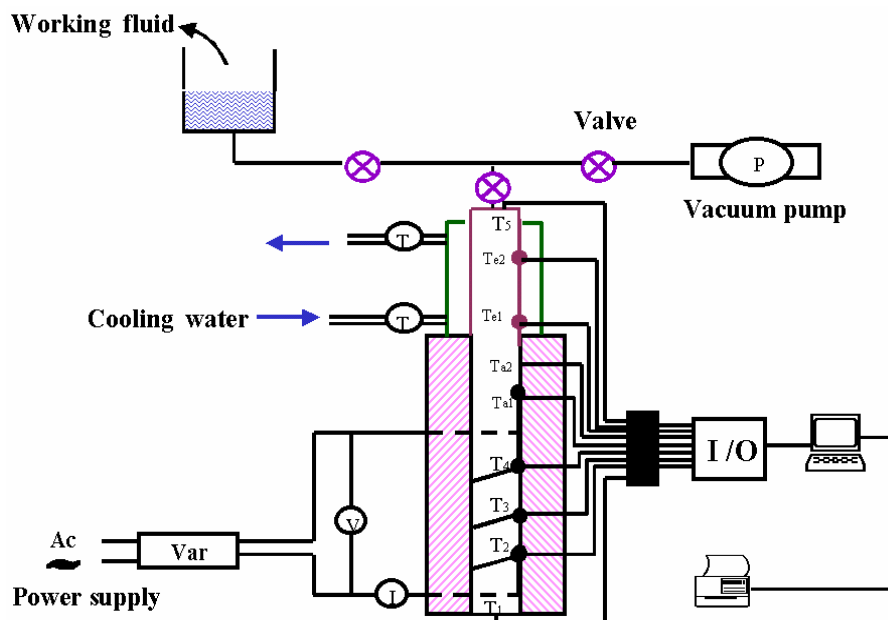

Figure 2. Schematic of the experimental apparatus.

(Le/D). A copper jacket with a diameter of 50 mm surrounds the condenser section, and cooling water flows through the annular passage that is measured by a rotameter with an accuracy of $\pm 3\%$. The output temperatures were recorded on a data logger connected to personal computer for analysis of the data. The saturation temperature of the vapor and water were read by thermocouples installed inside the top and bottom of the pipe, respectively. A rotary vacuum pump and diffusion pump with a rating to -86kPa were used to remove air and other non-condensable gases from the system.

3. CALCULATION PROCEDURE

The heat transfer rate to the evaporator section by electric elements is calculated from the following relation:

$$\dot{Q}_{in} = VI \quad (1)$$

The rate of heat removal from the condenser section is obtained from the following relation:

$$\dot{Q}_{out} = \dot{m}c_p(T_o - T_i) \quad (2)$$

From the measured data on wall temperature distribution, vapor temperature and the value of the thermal load, the average heat transfer coefficients of boiling (h_e) and condensation (h_c) can be evaluated using the following equations:

$$h_e = \frac{\dot{Q}_{in}}{\pi IDL_e(T_{e,m} - T_{sat})} \quad (3)$$

$$h_c = \frac{\dot{Q}_{out}}{\pi IDL_c(T_{sat} - T_{c,m})} \quad (4)$$

where $T_{e,m}$ and $T_{c,m}$ denote the mean values of the wall temperatures at the evaporator and condenser, respectively, and T_{sat} denotes the saturation temperature of the vapor inside thermosyphon.

3-1. Correlations of Boiling In the previous studies, it was found that nucleate boiling is the dominant mechanism in the evaporator, when the filling ratio is higher than 30%. Therefore, the following two correlations based on nucleate boiling were chosen to compare with the experimental data.

Rohsenow [13] correlated experimental data for nucleate pool boiling with the following relation:

$$h_e = \frac{q_e^{2/3}}{\frac{C_{sf} h_{fg}}{c_p} \left\{ \frac{1}{h_{fg} \mu_l} \left(\frac{\sigma}{g[\rho_l - \rho_v]} \right)^{1/2} \right\}^{0.33} Pr} \quad (5)$$

The values of the constant C_{sf} are given in most of heat transfer text.

Imura's correlation [14] is as follows:

$$h_e = 0.32Z \left(\frac{P_{sat}}{P_{atm}} \right)^{0.3} \quad (6)$$

where

$$Z = \frac{\rho_l^{0.65} k_l^{0.3} c_p^{0.7} g^{0.2} q_e^{0.4}}{\rho_v^{0.25} h_{fg}^{0.4} \mu_l^{0.1}} \quad (7)$$

3-2. Correlation of Condensation In general, the dominant flow regime inside the condenser of a thermosyphon is known to be counter current annular flow, with a condensate film flowing downward on the wall surface and vapor flow moving upward through the tube core. The correlation described below is based on the analysis of falling condensate films, and will be compared with the present data.

Nusselt's model Nusselt [4] derived an expression for the condensation heat transfer coefficient described in the following equation from a theoretical analysis of laminar condensate flow.

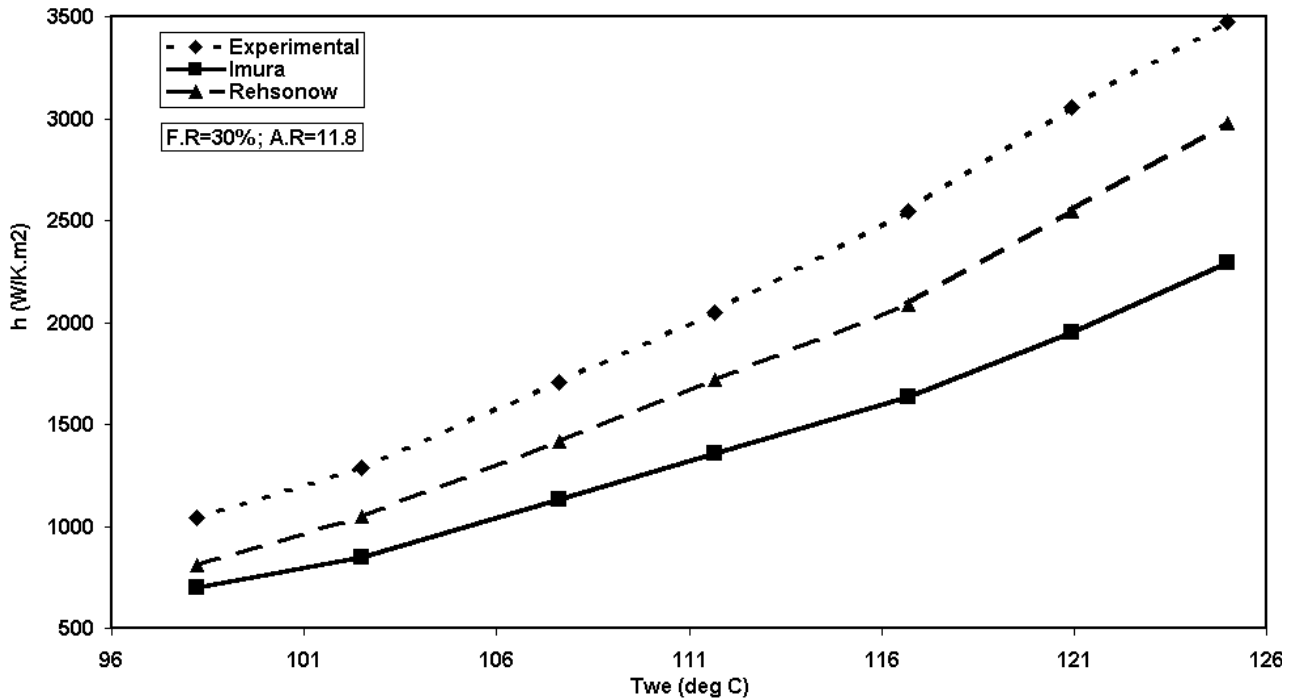

Figure 3. Comparison of boiling heat transfer coefficient with existing correlations for A.R=11.8 & F.R=30%.

$$h_c = 0.943 \times \left\{ \frac{\rho_l g k_l^3 (\rho_l - \rho_v) [h_{lv} + 0.68 C_{p,l} (T_{sat} - T_w)]}{\mu_l L_c [T_{sat} - T_w]} \right\}^{1/4} \quad (8)$$

Figure 3 for an aspect ratio of 11.8 and a filling ratio of 30%. The experimental results are also compared with those of Imura and Rohsenow's correlations in this figure. As shown in Figure 3, the agreement between the experimental results with Rohsenow's correlation is better.

4. RESULTS AND DISCUSSION

Experimental investigations were carried out on the effect of various parameters on the thermal performance of a two-phase closed thermosyphon focusing on boiling and condensation heat transfer. The experimental results and comparisons between the experiments and existing correlations are as follow.

4-1. Boiling Heat Transfer Coefficient The variation of experimental boiling heat transfer coefficients, h_e , with respect to the average temperature of evaporator surface are shown in

4-2. Condensation Heat Transfer Coefficient

Figure 4 shows the variation of saturation temperature of the vapour inside the condenser against the surface temperature of the evaporator section of the thermosyphon for A.R=11.8 and F.R=30. These are experimental results and have also been compared with Nusselt's theory [4]. A good agreement (less than 5% discrepancy) between the experimental results and Nusselt's Model has been observed.

4-3. Overall Heat Transfer Coefficient The input heat transfer rates versus the temperature difference between the evaporator and condenser

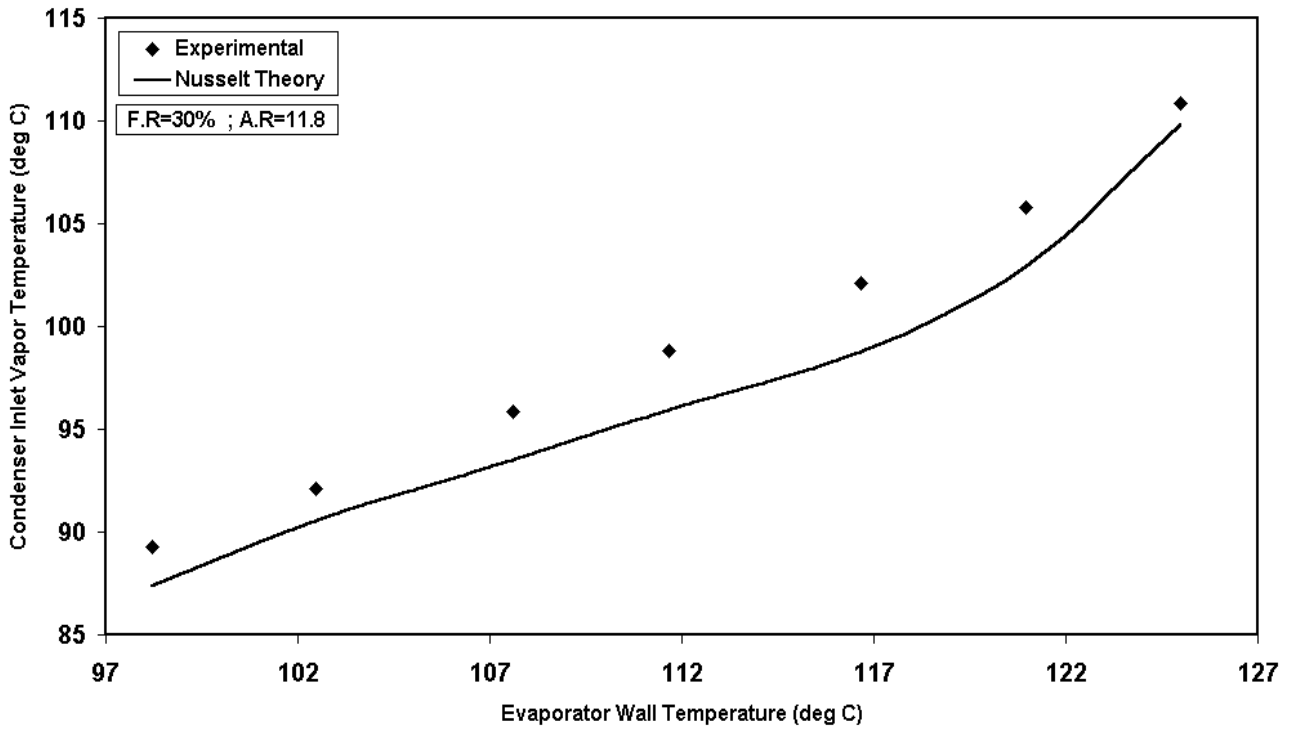

Figure 4. Variation of saturation temperature of the vapor inside the condenser versus the evaporator wall temperature.

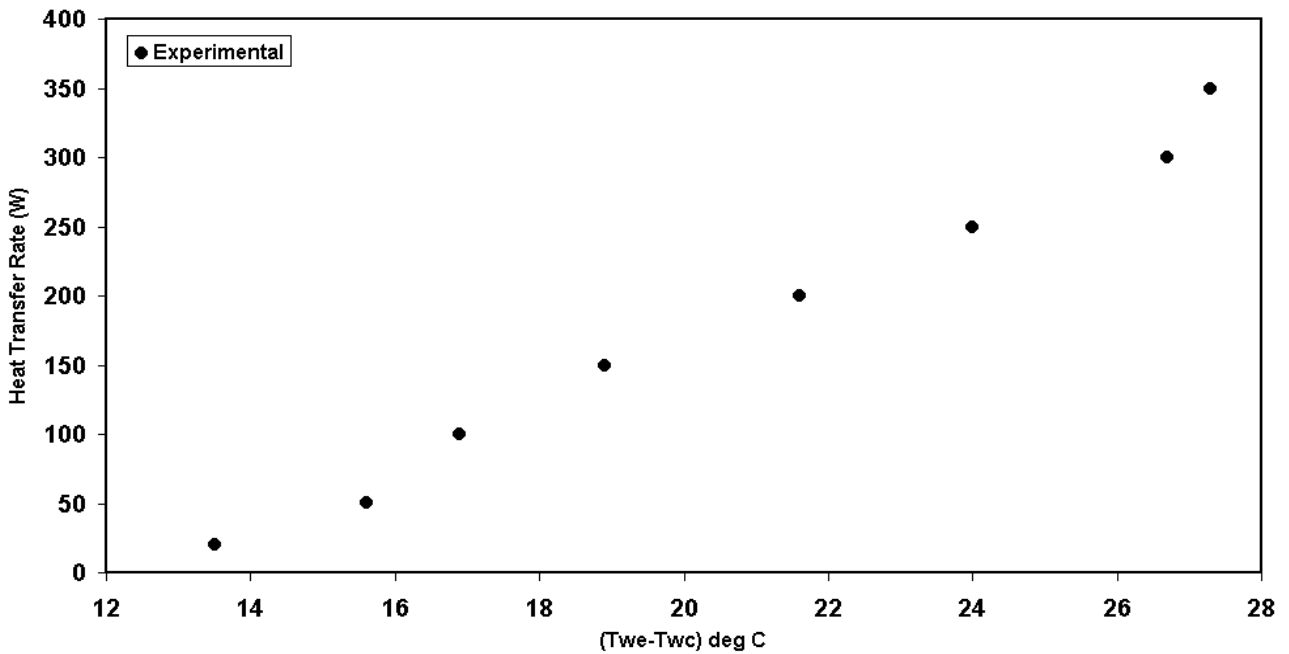

Figure 5. Variation of input power versus the temperature difference between the evaporator and condenser.

sections are plotted in Figure 5. The average overall heat transfer coefficient is obtained from Equation 9.

$$U = \frac{q_e}{T_{e,m} - T_{c,m}} \quad (9)$$

The overall heat transfer coefficient is about 96000 W/m².°C. Therefore, the heat flux of the thermosyphon is about 250 times the value of a copper rod with the same dimensions. This is one of the important advantages of thermosyphons.

4-4. Optimum Working Fluid Figure 6 shows the variation of the heat transfer rate against mass percentage of working fluid inside

the evaporator for an aspect ratio of 11.8 and two different average temperatures of the evaporator sections. As can be seen for A.R = 11.8, the optimum mass of working fluid for maximum input power occurs when the F.R = 60%, that is equivalent to 182gr water for both cases. The variation of the heat transfer rate with respect to filling ratio is shown in Figure 7. for aspect ratio of 9.8 and two different average temperatures of evaporator sections. The highest input heat for A.R = 9.8 occurs when the F.R = 30%.

4-5. Prediction of the Boiling Heat Transfer Coefficient, h_e According to previous research results and the experimental results of this work,

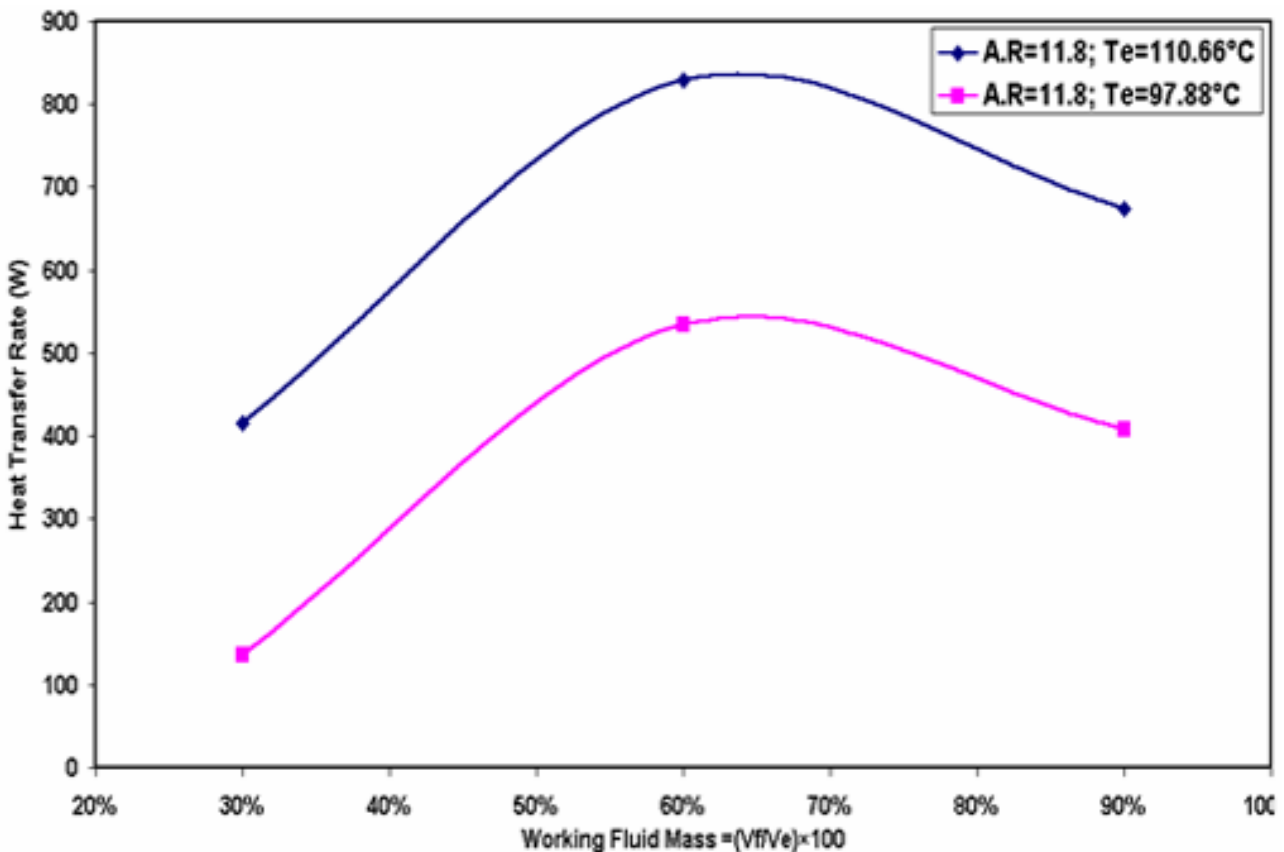

Figure 6. Optimum working fluid for A.R = 11.8.

it is concluded that the boiling transfer coefficient depends on the aspect ratio, filling ratio, input heat to evaporator section, and saturation pressure of working fluid. In order to predict the boiling heat transfer coefficient generally, the data of h_e from all experimental results were correlated with the related parameters with phenomena inside the thermosyphon. The working conditions have been analyzed and a new practical formula (correlation) is recommended as follow:

$$h_e = 4.7882 \times q^{0.6714} \times (p^{sat})^{0.2565} \times (FR)^{0.0044} \times (AR)^{0.0287} \quad (10)$$

5. CONCLUSIONS

The results of thermal performance of a vertical two-phase closed thermosyphon focusing on boiling and condensation heat transfer gave the following conclusions:

1. The experimental results of condensation inside the thermosyphon were compared with the correlation derived from Nusselt's theory and reasonable agreement was obtained.
2. The boiling heat transfer coefficient was compared with correlations of Imura and Rohsenow. The results at this work had better agreement with that of Rohsenow correlation.
3. Experimental values of the overall heat transfer coefficient showed that the heat flux

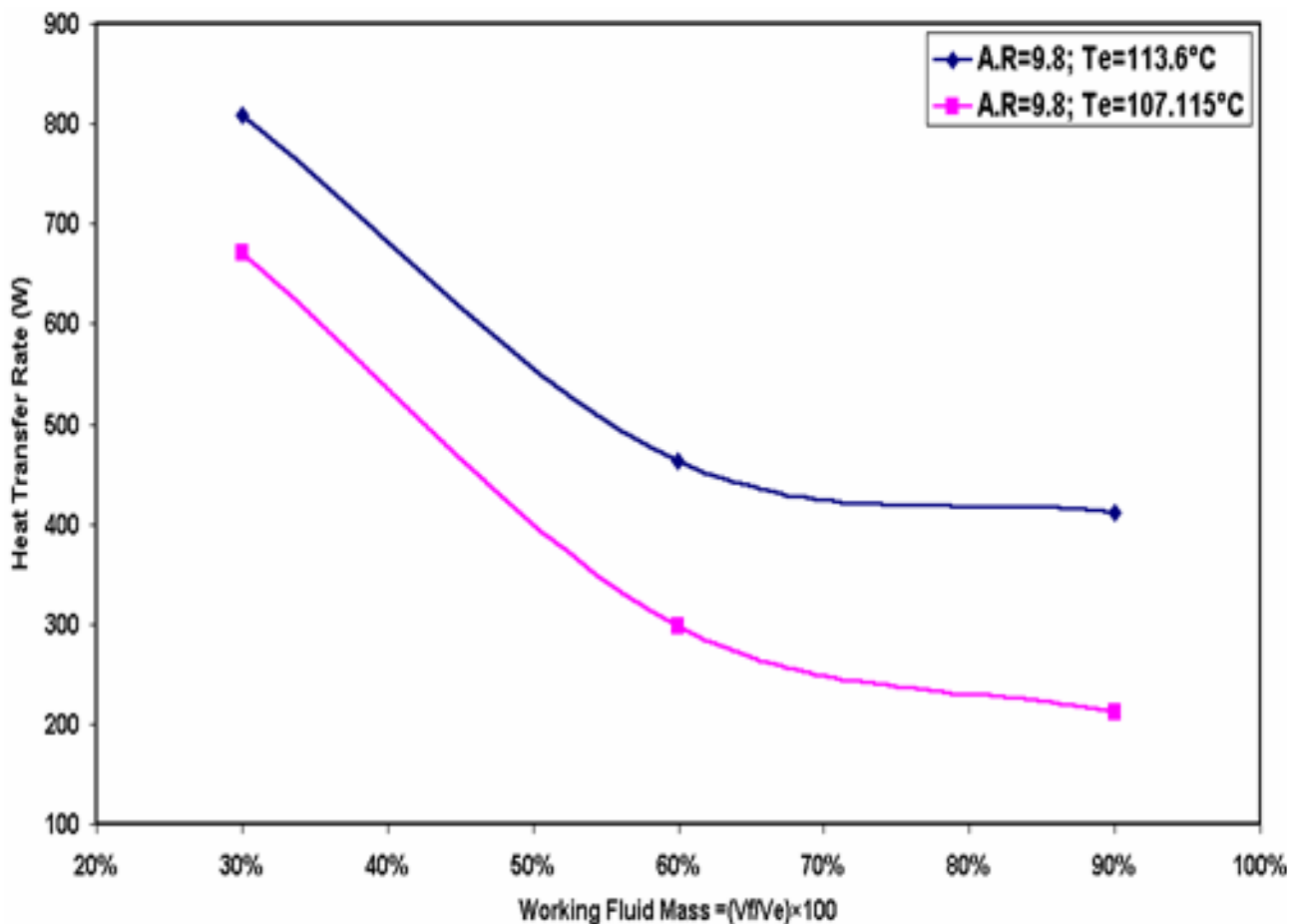

Figure 7. Optimum working fluid for A.R = 9.8.

of the thermosyphon was nearly 250 times the values of a copper rod with the same dimensions.

4. Maximum heat transfer rates for each aspect ratio occurred at different filling ratios. For an aspect ratio of 9.8 the maximum heat transfer rate occurs when the filling ratio is 60%, while for an aspect ratio of 11.8 the highest value occurs at filling ratio of 30%.
5. Finally, in order to predict boiling heat transfer coefficient generally, a new practical formula was correlated.

6. NOMENCLATURE

A.R	aspect ratio
C_{sf}	constant, determined from experimental data
c_p	specific heat of water (J/kg.°C)
g	gravitational acceleration (m/s ²)
F.R	filling ratio
k_l	thermal conductivity of liquid (W/m.°C)
h_e	boiling heat transfer coefficient (W/m ² .°C)
h_{fg}	latent heat of vaporization (J/kg)
I	current (A)
ID	inside diameter of tube (m)
L_a	length of adiabatic section (m)
L_c	length of condenser section (m)
L_e	length of evaporator section (m)
\dot{m}	mass flow rate of water in condenser (kg/s)
OD	outside diameter of tube (m)
Pr	Prandtl number
P_{atm}	atmospheric pressure (Pa)
P_{sat}	saturated pressure (Pa)
q_e	heat flux (W/m ²)
\dot{Q}_{in}	inlet heat by evaporation (W)
\dot{Q}_{out}	outlet heat by condensation (W)
	$\dot{Q}_{av} = \frac{\dot{Q}_{in} + \dot{Q}_{out}}{2}$ average of heat transfer rate (W)
$T_{e,m}$	average temperature of evaporator section (°C)
$T_{c,m}$	average temperature of condenser section (°C)

T_i	inlet water temperature of condenser (°C)
T_o	outlet water temperature of condenser (°C)
T_{sat}	saturation temperature of the vapor (°C)
V	voltage (V)
ρ_l	density of liquid (kg/m ³)
ρ_v	density of vapor (kg/m ³)
μ_l	viscosity of liquid (kg/m.s)
σ	surface tension (N/m)

7. REFERENCES

1. Lin, S., Broadbent, J. and McGlen, R., "Numerical Study of Heat Pipe Application in Heat Recovery Systems", *Applied Thermal Engineering*, 25, (2005), 127-133.
2. Farsi, H., Joly, J. L., Miscevic, M., Platel, V. and Mazet, N., "An Experimental and Theoretical Investigation of the Transient Behavior of a Two-Phase Closed Thermosyphon", *Applied Thermal Engineering*, 23 (2003), 1895-1912.
3. Dunn, P. D. and Reay, D. A., "Heat Pipes", 3rd. Ed. Pergamon Press, (1994).
4. Faghri, A., "Heat Pipe Science and Technology", Taylor and Francis, USA, (1995).
5. Imura, H., Sasaguchi, K., Kozai, H. and Numata, S., "Critical Heat Flux in a Closed Two-Phase Thermosyphon", *Int. J. Heat and Mass*, Vol. 26, (1983) 1181-1188.
6. Shirashi, M., Kikuchi, K. and Yamanish, T., "Investigation of Heat Transfer Characteristics in Heat Pipe Technology", (Edited by Reay), Pergamon Press, New York, (1981), 95-104.
7. Kaminaga et al., "Study on Boiling Heat Transfer Correlation in a Two-Phase Closed Thermosyphon", *Proceeding of 8th International Heat Pipe Conference*, (1992), 317-322.
8. Alabovsky, A. N., Bezrodnyi, M. K. and Moklyak, V. F., "Study of Vapor Condensation Heat Transfer in Vertical Thermosyphons", *IZV. Vnzov Energetika*, Vol. 7, (1979), 61-67.
9. Pan, Y., "Condensation Heat Transfer Characteristics and Concept of Sub-Flooding Limit in a Two-Phase Closed Thermosyphon", *International Communication of Heat Transfer*, Vol. 28, (2001) 311-322.
10. Pan, Y. and Wu, C. Z., "Condensation Deterioration and Sub-Flooding Limit in Heat Pipes", *The 12th International Heat Pipe Conference (12IHPS)*, Moscow, Russia, (2002), 291-295.
11. Hong, S. E., Kim, C. J., Park, Y. J. and Kang, H. K., "An Experimental Study on the Heat Transfer Characteristics of a FC-72 Thermosyphon", *12th International Heat Pipe Conference*, Moscow, (2002), 308-314.
12. Lee, Y. and Bedrossian, A., "The Characteristics of Heat Exchangers Using Heat Pipes or Thermosyphons", *International Journal of Heat and Mass Transfer*, Vol.

- 21, (1978) 221-229.
13. Rohsenow, W. M., "A Method of Correlating Heat Transfer Data for Surface Boiling Curves", *International Journal of Heat Transfer ASME*, Vol. 84, (1962), 969.
 14. Imura, H., Kusada, H., Oyata, J., Miyazaki, T. and Sakamoto, N., "Heat Transfer in Two-Phase Closed Thermosyphon", *Trans. of Japan Soc. of Mech. Eng.*, (1977), 485-493.